



**ADDENDUM NO.:** 3

**Description:** Furnish and Deliver Medium Voltage Pad-Mounted Switch Gear

**Project:** 3590009999

**Bid Due Date:** January 23, 2024

**Specifics of the Addendum:** Change to specifications and Bid Due Date.

Please see the attached specifications with updates to Sections 2.1, 2.6, 2.7, 2.9 and 3.0.

The Bid Opening Date/Bid Due Date has been changed to January 23, 2024 at 2:00p.m.



**DASNY**



**Office of  
Mental Health**

515 BROADWAY  
ALBANY, NY 12207-2964  
518.257.3000

28 LIBERTY STREET  
55<sup>TH</sup> FLOOR  
NEW YORK, NY 10005-1400  
212.273.5000  
800.992.2788

6047 TRANSIT ROAD  
SUITE 103  
EAST AMHERST, NY 14051  
716.566.4400

3495 WINTON PLACE  
BUILDING C, SUITE 1  
ROCHESTER, NY 14623  
585.450.8400

THESE DOCUMENTS CONTAIN POTENTIALLY SENSITIVE INFORMATION AND SHALL BE USED FOR THEIR INTENDED PURPOSE. ONCE THE INTENDED PURPOSE HAS CEASED, THE DOCUMENTS SHALL BE DESTROYED IN A SECURE MANNER.

IT IS A VIOLATION OF STATE EDUCATION LAW FOR ANY PERSON, UNLESS UNDER THE DIRECTION OF A LICENSED ARCHITECT/ENGINEER TO ALTER THIS DOCUMENT IN ANYWAY. ALTERATIONS MUST HAVE THE SEAL AFFIXED ALONG WITH A DESCRIPTION OF THE ALTERATIONS, DATE AND ARCHITECT'S/ENGINEER'S SIGNATURE. COPYRIGHT © 2022

**MID-HUDSON FORENSIC PSYCHIATRIC  
REPLACEMENT HOSPITAL  
ELECTRICAL EQUIPMENT PREPURCHASE**

**OFFICE OF MENTAL HEALTH  
MID-HUDSON FORENSIC PSYCHIATRIC CENTER**

2 RIVER ROAD  
NEW HAMPTON, NY 10958

**DASNY PROJECT NUMBER: 3590009999**

**CLIENT NUMBER: 3020829**

**DATE: 11/09/2023**

**ELECTRICAL EQUIPMENT PREPURCHASE**

**VOLUME 1 OF 1**

**STV and A|r, A JOINT VENTURE**

225 PARK AVENUE SOUTH  
NEW YORK, NY 10003  
212-777-4400

***Seals & Signatures***

## Table of Contents

### Prepurchase Package

#### DIVISION 01 – GENERAL REQUIREMENTS

011200 CONTRACT SUMMARY OF WORK

#### DIVISION 26 - ELECTRICAL

261219 PAD-MOUNTED, LIQUID-FILLED, MEDIUM-VOLTAGE TRANSFORMERS

261329 MEDIUM-VOLTAGE, METAL-CLAD SWITCHGEAR

#### DRAWINGS

E-1 PREPURCHASE SITEPLAN #1

E-2 PREPURCHASE SITEPLAN #2

SKE-1 GOAB SWITCH DETAILS

#### REFERENCE DOCUMENTS

E-101A ELECTRICAL SITE UTILITIES PLAN #1 (WORK BY OTHERS)

E-101B ELECTRICAL SITE UTILITIES PLAN #2 (WORK BY OTHERS)

END OF TOC

## ELECTRICAL EQUIPMENT PREPURCHASE CONTRACT SUMMARY OF WORK

### PART 1 - GENERAL

#### 1.1 RELATED DOCUMENTS

- A. The Contract Documents, including but not limited to the Drawings and Individual Specification Sections, apply to this Section.

#### 1.2 SUMMARY

- A. Section includes a summary of the Contract for the Project, including responsibilities for coordination and temporary facilities and controls.
- B. Specific requirements for the work of the Contract are also indicated in individual Specification Sections and on Drawings.

#### 1.3 COORDINATION ACTIVITIES

- A. Coordination activities of the Contractor are not limited to the following:
  - 1. Provide overall coordination of the Work with all Contractors and Sub-Contractors.
  - 2. Coordinate the shared access to workspaces to allow the Work of the Contract to proceed per the Master Project schedule for the BP-1 Contract and other Work Contracted through separate contracts with/by the Owner.
  - 3. Coordinate product selections for compatibility with either product selected under this Contract and under other Contracts for the Project. Identify to the Owner and/or Owner's Representative and Design Professional incompatibilities between products selected under this Contract and products selected under other Contracts for the Project.
  - 4. Coordinate construction and operations of the Contractors Work with Work performed by each Separate Contract for the Project, including but not limited to those contracts listed in section 1.4A.4.a.
  - 5. Coordinate sequencing and scheduling of delivery and storage of equipment.
  - 6. Coordinate sequence of activities to accommodate tests and inspections, and coordinate schedule of tests and inspections. Requests for Owner and/or Owner's Representative furnished testing and inspection services shall be made in writing to the Owner's Representative 48 hours in advance.
  - 7. Submit all required project turnover documents.
  - 8. Coordinate preparation of operation and maintenance manuals.

#### 1.4 GENERAL REQUIREMENTS OF CONTRACT

- A. Extent of Contract: Requirements indicated on drawings and in specification sections determine which Contract includes a specific element of the Work of the Contract.
1. The work described in this section for each Contract shall be complete systems and assemblies, including products, components, and accessories included in the respective Contract documents.
  2. Vendor's Preliminary Schedule: Within seven (7) working days after Contract Award, the Vendor is to provide their preliminary CPM schedule submittal to the Owner's Representative.
  3. Contractor's Monthly Schedule Update: Utilizing the software required by
  4. The following contracts have or will be awarded by the Owner as separate work from the Work of this Contract ([See 4.a. below](#)). The Work of this Contractor requires coordination with the separate contract. Volumes include information on the following separate contracts so that the Contractor may evaluate and account for any cost or time impact to their Work and bid price. The Contractor's Work in this contract shall comply with the requirements of The Contract including Article 4, Section 4.08 Related Work; Section 4.09 Coordination with Separate Contracts and Section 4.10 Cooperation with Other Contractors.:
    - a. Separate Contracts Related to the Work of this Contract:
      - 1) **Electrical Equipment Prepurchase Package (this contract)**
      - 2) BP-1 Site Readiness Package
      - 3) BP-2 Base Building Package
      - 4) BP-3 Sewer Water Package
- B. Substitutions: Project Managers shall cooperate with all other Contractor's Project Managers involved in the Project to coordinate approved substitutions with remainder of the work of the Project.
- C. (Not used)
- D. (Not Used)
- E. Normal Working Days, Holidays and Hours in conformance to the Project Labor Agreement:
  1. Normal working days are Monday through Friday.
  2. Normal working hours are 7:00am - 4:00pm, subject to change at the discretion of the Owner with notice to the Contractor.
  3. Normal holidays are the limited to the holidays listed in the PLA.
- F. (Not Used).

#### PART 2 - SUMMARY OF WORK

- A. Extent of Contract: Requirements indicated on drawings and in specification sections determine

specific element of the Work of the Contract. The work described in this section for each Contract shall be complete systems and assemblies, including products, components, and accessories, as required by the respective Contract documents.

- B. Work in the Construction Contract is as indicated in the Contract Plans and Specifications and includes, but is not limited to, the following:

*Bidder's Note: the following outline of the scope of work under this Contract is provided to assist the Bidder in the initial identification and evaluation of the major items of work required. The following listing and description of work items are described in general terms only and does not represent a comprehensive listing of all the work under the contract.*

*The Bidder is hereby referred to the remainder of the contract documents for a comprehensive description of work required under this contract.*

*Provide all labor, materials, plant services, equipment, and incidental items, as required and proper to perform the work in accordance with the applicable requirements of the various portions of the Contract Documents.*

- C. General Note for Work included in Bid Package 1:
1. All Work unless noted as Not in Contract (NIC)
  2. All furnishings and equipment as required by the Contract.
  3. Execution of Contract in accordance with safety requirements and OSHA Standards.

## 1.2 ELECTRICAL EQUIPMENT PREPURCHASE

- A. The vendor shall supply the following:

1. (1) 400 kVA Transformer to serve DASNY/CM trailers, Water Towers and Cell Towers
2. (1) 400 kVA Transformer to serve temporary power during construction of BP2
3. (1) 500 kVA Transformer to serve temporary power during construction of BP2
4. (1) Service Switchgear
5. (1) GOAB switch (to be pole mounted in BP1)
6. (1) Switch/NEMA 3R enclosure

- B. Schedule: equipment shall be procured, delivered, and stored on the site no later than June 12, 2024.**

## 1.3 WORK BY OTHERS (FOR REFERENCE)

- A. Equipment furnished by this contract shall be installed under the BP1 contract. Refer to reference documents included.

END OF SECTION 011200

## SECTION 261329 – PRE-PURCHASE - MEDIUM-VOLTAGE, PAD-MOUNTED SWITCHGEAR

### PART 1 - GENERAL

#### 1.1 RELATED DOCUMENTS

- A. Drawings and general provisions of the Contract, including General and Supplementary Conditions and Division 01 Specification Sections, apply to this Section.

#### 1.2 SUMMARY

- A. Section includes dead-front, remotely controlled insulated vacuum load and fault interrupting switchgear.

#### 1.3 DEFINITIONS

- A. BIL: Basic Impulse Insulation Level.
- B. Bushing: An insulating structure including a central conductor, or providing a central passage for a conductor, with provision for mounting on a barrier, conducting or otherwise, for insulating the conductor from the barrier and conducting current from one side of the barrier to the other.
- C. Bushing Elbow: An insulated device used to connect insulated conductors to separable insulated connectors on dead-front, pad-mounted switchgear and to provide a fully insulated connection. Also called an "elbow connector."
- D. Bushing Insert: That component of a separable insulated connector that is inserted into a bushing well to complete a dead-front, load break or non-load break, separable insulated connector (bushing).
- E. Bushing Well: A component of a separable insulated connector, either permanently welded or clamped to an enclosure wall or barrier, having a cavity that receives a replaceable component (bushing insert) to complete the separable insulated connector (bushing).
- F. Fault Interrupter: A self-controlled mechanical switching device capable of making, carrying, and automatically interrupting an alternating current. It includes an assembly of control elements to detect overcurrents and control the fault interrupter. A fault interrupter always consists of a switching device, a control unit, and sensors for current and/or voltage sensing.
- G. Hotstick: An insulated stick, usually made of fiberglass, that is used to work energized overhead conductors and operate electrical equipment that is overhead, underground, and compartmentalized.
- H. NETA ATS: Acceptance Testing Specification.

- I. SCADA: Supervisory control and data acquisition.
- J. Way: A three-phase or single-phase circuit connection to the bus that may contain combinations of switches and protective devices or may be a solid bus.

#### 1.4 ACTION SUBMITTALS

- A. Product Data: For each type of product.
  - 1. Include rated capacities, operating characteristics, and furnished specialties and accessories.
  - 2. Time-current characteristic curves for overcurrent protective devices.
- B. Shop Drawings: For pad-mounted switchgear.
  - 1. Include plans and elevations showing major components and features.
    - a. Include a plan view and cross section of equipment base showing clearances, required work space, and locations of penetrations for grounding and conduits.
  - 2. Include details of equipment in each way and indicate dimensions, weights, loads, required clearances, and location and size of each field connection.
  - 3. Include single-line diagram.
  - 4. Include list of materials.
  - 5. Include nameplate data.
  - 6. Include control power wiring diagrams.
  - 7. Include battery, charger, and transfer switch ratings.
  - 8. Include copy of nameplate.
  - 9. Switchgear Ratings:
    - a. Voltage.
    - b. Continuous current.
    - c. Short-circuit rating.
    - d. BIL.
  - 10. Design Calculations: Signed and sealed by a qualified professional engineer.
  - 11. Wiring Diagrams: For each switchgear assembly, include the following:
    - a. Power, signal, and control wiring.
    - b. Schematic diagrams showing connections to remote devices.

#### 1.5 INFORMATIONAL SUBMITTALS

- A. Coordination Drawings:



1. Utilities site plan, drawn to scale, showing heavy equipment or truck access paths for maintenance and replacement.
  - B. Qualification Data: For testing agency.
  - C. Product Certificates: For pad-mounted switchgear.
    1. Switch ratings as listed in IEEE C37.74.
    2. Interrupter ratings as listed in IEEE C37.60.
    3. Coating system compliance with the IEEE standard listed in "Enclosure" Article.
  - D. Source quality-control reports.
  - E. Field quality-control reports.
- 1.6 CLOSEOUT SUBMITTALS
- A. Operation and Maintenance Data: For switchgear and switchgear components to include in emergency, operation, and maintenance manuals.
    1. In addition to items specified in Section 017823 "Operation and Maintenance Data," include the following:
      - a. Manufacturer's written instructions for testing and adjusting overcurrent protective devices.
      - b. Time-current curves, including selectable ranges for each type of overcurrent protective device.
      - c. Record as-left set points of adjustable devices.

1.7 QUALITY ASSURANCE

- A. Testing Agency Qualifications: Member company of NETA.
  1. Testing Agency's Field Supervisor: Certified by NETA to supervise on-site testing.

PART 2 - PRODUCTS

2.1 MANUFACTURERS

1. ABB Control, Inc.
2. Eaton Corporation; Cutler-Hammer Products.
3. S&C Electric Company.
4. Siemens Energy & Automation, Inc.

## 2.2 SYSTEM DESCRIPTION

- A. Manufactured Unit: Pad-mounted switchgear, designed for application in impedance-grounded underground distribution systems.
- B. Electrical Components, Devices, and Accessories: Listed and labeled as defined in NFPA 70, by a qualified testing agency, and marked for intended location and application.
- C. Comply with IEEE C2.
- D. Comply with IEEE C37.74.

## 2.3 PERFORMANCE REQUIREMENTS

- A. Service Conditions:
  - 1. Switchgear shall be suitable for operation under service conditions specified as usual service conditions in IEEE C37.20.3

## 2.4 RATINGS

- A. Switchgear is applied to a nominal 13.2kV (L-L) medium-voltage electrical power system. Minimum ratings of the switchgear shall be as follows:
  - 1. Rated Maximum Voltage and Rated BIL: 27 kV and 125 kV BIL.
  - 2. Continuous and Load Interrupting Current: 600 A.
  - 3. Short-Time and Short-Circuit Interrupting Current: 16 kA rms Sym.

## 2.5 ENCLOSURE

- A. Weatherproof enclosure with an integral skid mounting frame, designed for mounting on a concrete pad, suitable to allow skidding or rolling of the switchgear in any direction, and with provision for anchoring the frame to the pad.
- B. Enclosure Integrity: Comply with IEEE C57.12.28 for compartmentalized enclosures that contain energized electrical equipment in excess of 600 V that may be exposed to the public.
- C. Corrosion Protection: Fabricate the support frame, enclosure base, and the enclosure from stainless steel, ASTM A 167, Type 304 or 304L. Enclosure coating system shall be factory applied, meeting the requirements of IEEE C57.12.28, standard color.

## 2.6 CONSTRUCTION

- A. Dead-front, front and rear access switchgear.

- B. Each disconnect switch in switched ways shall be in a sealed, dielectric filled stainless-steel tank, factory-filled with **mineral oil** or less-flammable, high-firepoint fluid.
  - 1. Mineral Oil: Comply with ASTM D 3487, Type II, and tested for compliance with ASTM D 117. Provide enclosure with level gauge to monitor the dielectric level; automatic pressure relief valve; and fill, drain, and sampling valves.
  - 2. Less-flammable, high-firepoint fluid shall comply with ASTM D 6871 and IEC 61099. The temperature rating of the fluid shall be satisfactory for ambient air temperatures of minus 30 deg C and plus 40 deg C. Provide enclosure with level gage to monitor the dielectric level; automatic pressure relief valve; and fill, drain, and sampling valves.
- C. Construct switchgear assembly with switched ways that have front-accessible terminations for cables entering from below and with manual operating provisions with a lineman's hotstick.
- D. Trapped Key Interlocks: Kirk key interlock system using a dowel pin design having no openings. Brass housing and 316 stainless-steel key and lock bolts.
- E. Viewing Windows: For each switch, located adjacent to manual operating devices, and positioned to show switch contact position.
- F. Grounding: Provision to make grounding cable and wire connections at each way.

## 2.7 SWITCHED WAYS

- A. Source Switch Ways: Non-fused, hotstick operated, ganged vacuum load interrupter switches, in series with a visible-break disconnect switch.
  - 1. Rated Continuous Current and Load Switching Current: 600 A.
  - 2. Vacuum Load Interrupter:
    - a. With 24 V dc motor operators to open or close the load interrupter.
    - b. Trip-free switch mechanism. Closing the switch shall be independent of the speed of the operating handle.
  - 3. Visible-Break Disconnect Switch: Two positions, with open and closed positions. The switch shall be mechanically interlocked so that the vacuum interrupter opens and closes first.
    - a. Switch position indicator, clearly labeled.
    - b. Padlocking and tagging provisions.
- B. Fault Interrupting Switched Ways: Non-fused, hotstick-operated, ganged vacuum fault interrupter switches, in series with a visible-break disconnect. With internally mounted current transformers and electronic overcurrent sensing for three-phase ganged tripping of the interrupter. Comply with IEEE C37.60.
  - 1. Rated Continuous Current and Load Switching Current: 600 A.
  - 2. Vacuum Fault Interrupter:

- a. Operated by a motor-charged stored energy mechanism, with provision to manually charge the mechanism. Charging motors shall operate at 24 V ac.
  - b. Auxiliary Switches: Provide two auxiliary switches, each with field-selectable NC or NO switch position, for connection of remote indication of the position of the switched way. The switches shall be rated at 15 A, 120 V ac, and 1 A, 120 V dc.
  - c. Trip-free switch mechanism when manually operated. Closing the switch shall be independent of the speed of the operating handle.
  - d. Single operating handle and a clearly labeled switch position indicator; open, closed, tripped.
  - e. Operations Counters: Mechanical type, linked to the operating handle of each switched way.
  - f. Padlocking and tagging provisions.
3. Visible-Break Disconnect Switch: Two positions, with open and closed positions. The switch shall be mechanically interlocked so that the switch cannot be operated unless the vacuum fault interrupter is open.
    - a. Switch position indicator, clearly labeled.
    - b. Padlocking and tagging provisions.
- C. Controls:
1. Motor Actuators: "Open," "close," and "stop" push buttons.
  2. Switch Status LEDs: "Open" and "closed" lights. Show status of disconnect switch using its auxiliary contact.
  3. Motor Actuator Process LEDs: "Opening" and "closing" lights indicating that the selected motor is operating the switch.
  4. Power Switch: "On" and "off" toggle switch and circuit protector, to disconnect the dc supply to its motor and provide overload and short-circuit protection.
  5. 120 V ac LED to display battery system power level.
  6. Battery voltage meter to show battery condition.
  7. Local and Remote Selector: In the "local" position remote operation of the switches is disabled and is possible only under the control of switchgear-mounted push buttons.
- D. Overcurrent and Control Relays: Field-adjustable microprocessor electronic relays in each phase at indicated locations. Provide for current adjustment from 0 to 600 A.
1. Device Functions: 51/50, 51N/50N, or 51G/50G according to IEEE C37.2.
- 2.8 POWER SUPPLY
- A. The power supply for instrumentation, communications, and switch operations shall be from a potential transformer installed as part of the switchgear.
  - B. The power supply for instrumentation, communications, and switch operations shall be from a 24 V dc power supply installed as part of the switchgear with the following characteristics:
    1. An integral power transformer.

2. An alternate power supply consisting of a 24 V dc uninterruptible power supply with a sealed lead-acid gel-cell maintenance free battery system.
  - a. The battery system shall be sized to meet all power demands, including the operation of all motor-operated switches in the pad-mounted switchgear at least once in a 24-hour period.
3. An automatic transfer switch to connect the alternate power supply when the primary power supply has failed.

## 2.9 AUTOMATIC SOURCE TRANSFER CONTROLS

- A. An automatic switch control system shall execute manual, automatic source-transfer, and SCADA operation of the source and fault interrupting switch ways. The source-transfer controls shall open an incoming switch way where voltage is lost and close the other incoming switch way if voltage is present. The controls shall include an overcurrent lockout that prevents the closing of a switch way into a system fault.
- B. The control shall have communication port provisions for connection to a multi-mode serial fiber link.

## 2.10 CONTROL NETWORK

- A. Controllers: Support serial MS/TP and Ethernet IP communications; able to communicate directly via RS-485 serial networks and Ethernet 10Base-T networks as a native device.

## 2.11 BUSHINGS

- A. Separable insulated connectors shall be used to connect primary cable. Comply with requirements in Section 260573 "Medium-Voltage Cables."
  1. Bushings: One-piece, 600 A, BIL ratings the same as the connectors. Comply with IEEE 386.
  2. Supply a standoff bracket or parking stand for each bushing, mounted horizontally adjacent to each bushing.

## 2.12 SURGE ARRESTERS

- A. Distribution class; metal-oxide-varistor type, fully shielded, separable elbow type, suitable for plugging into the inserts. Comply with IEEE C62.11 and IEEE 386.
  1. Nominal System Line-to-Line Voltage: 13.2 kV rms.
  2. Maximum Continuous Operating Voltage: 15 kV rms.
  3. Duty-Cycle Voltage: 13.2 kV rms.

## 2.13 WARNING LABELS AND SIGNS

- A. Comply with requirements in Section 260553 "Identification for Electrical Systems" for labels and signs.
1. High-Voltage Warning Label: Self-adhesive warning signs on the outside of the high-voltage compartment door(s). Sign legend shall be "DANGER HIGH VOLTAGE" printed in two lines of nominal 2-inch (50 mm) high letters. The word "DANGER" shall be in white letters on a red background and the words "HIGH VOLTAGE" shall be in black letters on a white background.
  2. Arc-Flash Warning Label: Self-adhesive warning signs on the outside of the high-voltage compartment door(s), warning of potential electrical arc-flash hazards and appropriate personal protective equipment required.

## 2.14 SOURCE QUALITY CONTROL

- A. Factory Tests: Comply with requirements in IEEE C37.60 and IEEE C37.74 for testing procedures.
1. Circuit Resistance Test: Verify that switchgear contacts have been properly aligned and current transfer points have been properly assembled.
  2. Power-frequency dry withstand voltage test.
  3. Dielectric withstand test; one-minute dry power-frequency.
  4. Calibrate overcurrent devices for conformance to published time-current characteristic curves.
  5. Sealed Tank Leak Test:
    - a. Comply with IEC 62271-1 for test procedure for switchgear using SF6.
    - b. The test procedure for vacuum switchgear shall be as follows:
      - 1) Each vacuum tube shall be identified by its serial number. Its vacuum pressure level shall be tested by the manufacturer of the vacuum interrupter. Document the test results.
      - 2) After assembly of the switchgear way, test the vacuum pressure level of the vacuum tubes by the routine dielectric test across the open contacts. The test voltage shall be stated by the manufacturer. The dielectric test shall be carried out after the mechanical routine test.
  6. Operating tests shall verify the following:
    - a. Switch position indicators and contacts are in the correct position for both the open and closed positions.
    - b. Insulating medium quantity indicator (if provided) is functioning properly.
    - c. Circuit configuration is shown correctly.
    - d. Mechanical interlocks are in place and operative.
    - e. Position and polarity of current transformers meets requirements.
    - f. Control, secondary wiring, and accessory devices are connected correctly.

- g. Devices and relays actually operate as intended. Circuits for which operation is not feasible shall be checked for continuity.

PART 3 - EXECUTION

3.1 Not used.

END OF SECTION 261329

SECTION 261219 – PRE-PURCHASE PAD-MOUNTED, LIQUID-FILLED, MEDIUM-VOLTAGE TRANSFORMERS

PART 1 - GENERAL

1.1 RELATED DOCUMENTS

- A. Drawings and general provisions of the Contract, including General and Supplementary Conditions and Division 01 Specification Sections, apply to this Section.

1.2 SUMMARY

- A. Section includes pad-mounted, liquid-filled, medium-voltage distribution transformers, with primary and secondary bushings within or without air-terminal enclosures.

1.3 DEFINITIONS

- A. BIL: Basic Impulse Insulation Level.
- B. Bushing: An insulating structure including a central conductor, or providing a central passage for a conductor, with provision for mounting on a barrier, conducting or otherwise, for the purpose of insulating the conductor from the barrier and conducting current from one side of the barrier to the other.
- C. Bushing Elbow: An insulated device used to connect insulated conductors to separable insulated connectors on dead-front, pad-mounted transformers and to provide a fully insulated connection. This is also called an "elbow connector."
- D. Bushing Insert: That component of a separable insulated connector that is inserted into a bushing well to complete a dead-front, load break or nonload break, separable insulated connector (bushing).
- E. Bushing Well: A component of a separable insulated connector, either permanently welded or clamped to an enclosure wall or barrier, having a cavity that receives a replaceable component (bushing insert) to complete the separable insulated connector (bushing).
- F. Elbow Connector: See "bushing elbow" above.

1.4 ACTION SUBMITTALS

- A. Product Data: For each type of product.
  - 1. Include rated capacities, operating characteristics, and furnished specialties and accessories.



- B. Shop Drawings: For pad-mounted, liquid-filled, medium-voltage transformers.
  - 1. Include plans and elevations showing major components and features.
    - a. Include a plan view and cross section of equipment base, showing clearances, required workspace, and locations of penetrations for grounding and conduits.
  - 2. Include details of equipment assemblies and indicate dimensions, weights, loads, required clearances, method of field assembly, components, and location and size of each field connection.
  - 3. Include single-line diagram.
  - 4. Include list of materials.
  - 5. Include nameplate data.
  - 6. Manufacturer's published time-current curves of the transformer high-voltage fuses, with transformer damage curve, inrush curve, and thru fault current indicated.

#### 1.5 INFORMATIONAL SUBMITTALS

- A. Coordination Drawings:
- B. Qualification Data: For testing agency.
- C. Product Certificates: For transformers, signed by product manufacturer.
- D. Source quality-control reports.
- E. Field quality-control reports.

#### 1.6 CLOSEOUT SUBMITTALS

- A. Operation and Maintenance Data: For transformer and accessories to include in emergency, operation, and maintenance manuals.

#### 1.7 QUALITY ASSURANCE

- A. Testing Agency Qualifications: Member company of NETA or an NRTL.
  - 1. Testing Agency's Field Supervisor: Certified by NETA to supervise on-site testing.

### PART 2 - PRODUCTS

#### 2.1 SYSTEM DESCRIPTION

- A. Electrical Components, Devices, and Accessories: Listed and labeled as defined in NFPA 70, by a qualified testing agency, and marked for intended location and application.

- B. Comply with IEEE C2.
- C. Comply with IEEE C57.12.00.

## 2.2 PERFORMANCE REQUIREMENTS

- A. Windings Material: Aluminum or Copper.
- B. Surge Arresters: Comply with IEEE C62.11, Distribution Class; metal-oxide-varistor type, fully shielded, separable-elbow type, suitable for plugging into the inserts provided in the high-voltage section of the transformer. Connected in each phase of incoming circuit and ahead of any disconnecting device.
- C. Winding Connections: The connection of windings and terminal markings shall comply with IEEE C57.12.70.
- D. Efficiency: Comply with 10 CFR 431, Subpart K.
- E. Insulation: Transformer kVA rating shall be as follows: The average winding temperature rise above a 30 deg C ambient temperature shall not exceed 65 deg C and 80 deg C hottest-spot temperature rise at rated kVA when tested according to IEEE C57.12.90, using combination of connections and taps that give the highest average winding temperature rise.
- F. Tap Changer: External handle, for de-energized operation.
- G. Tank: Sealed, with welded-on cover. Designed to withstand internal pressure of not less than 7 psi (50 kPa) without permanent distortion and 15 psig (104 kPa) without rupture. Comply with IEEE C57.12.36.
- H. Enclosure Integrity: Comply with IEEE C57.12.28 for pad-mounted enclosures that contain energized electrical equipment in excess of 600 V that may be exposed to the public.
- I. Mounting: An integral skid mounting frame, suitable to allow skidding or rolling of transformer in any direction, and with provision for anchoring frame to pad.
- J. Insulating Liquids:
  - 1. Mineral Oil: ASTM D 3487, Type II, and tested for compliance with ASTM D 117.
  - 2. Less-Flammable Liquids:
    - a. Edible-Seed-Oil-Based Dielectric: Listed and labeled by an NRTL as complying with NFPA 70 requirements for fire point of not less than 300 deg C when tested according to ASTM D 92. Liquid shall be biodegradable and nontoxic, having passed the Organization for Economic Co-operation and Development G.L.203 with zero mortality, and shall be certified by the U.S. Environmental Protection Agency as biodegradable, meeting Environmental Technology Verification requirements.

- b. Biodegradable and Nontoxic Dielectric: Listed and labeled by an NRTL as complying with NFPA 70 requirements for fire point of not less than 300 deg C when tested according to ASTM D 92.

K. Corrosion Protection:

1. Transformer coating system shall be factory applied, complying with requirements of IEEE C57.12.28, in manufacturer's standard color.
2. Fabricate front sill, hood, and tank base of single-compartment transformers from stainless steel according to ASTM A 167, Type 304 or 304L, not less than No. 13 U.S. gage, complying with requirements of IEEE C57.12.28, standard color.
3. Base and Cabinets of Two Compartment Transformers: Fabricate from stainless steel according to ASTM A 167, Type 304 or 304L, not less than No. 13 U.S. gage. Coat transformer with manufacturer's standard green color coating complying with requirements of IEEE C57.12.28, in manufacturer's standard color.

## 2.3 THREE-PHASE TRANSFORMERS

A. Description:

1. Electrical Components, Devices, and Accessories: Listed and labeled as defined in NFPA 70, by a qualified testing agency, and marked for intended location and application.
2. Comply with IEEE C57.12.26.

B. Compartment Construction:

1. Single-Compartment Construction: Clamshell style, with provision for padlocking, hinged cover, and single-point latching.
2. Double-Compartment Construction: Individual compartments for high- and low-voltage sections, formed by steel isolating barriers that extend full height and depth of compartments, with hinged, lift-off doors and three-point latching, with a stop in the open position and provision for padlocking.

C. Primary Fusing: Designed and rated to provide thermal protection of transformer by sensing overcurrent and high liquid temperature.

1. 150-kV BIL current-limiting fuses, conforming to requirements of IEEE C37.47.
2. Interrupting Rating: 50,000 rms A symmetrical at system voltage.
3. Fuse Assembly: Bayonet-type, liquid-immersed, expulsion fuses in series with liquid-immersed, partial-range, current-limiting fuses. Bayonet fuse shall sense both high currents and high oil temperature to provide thermal protection to the transformer. Connect current-limiting fuses ahead of radial-feed load-break switch.
4. Provide bayonet fuse assembly with an oil retention valve and an external drip shield inside the housing to eliminate or minimize oil spills. Valve shall close when fuse holder is removed and an external drip shield is installed.

5. Provide a conspicuously displayed warning adjacent to bayonet fuse(s), cautioning against removing or inserting fuses unless transformer has been de-energized and tank pressure has been released.

D. High-Voltage Section: Dead-front design.

1. To connect primary cable, use separable insulated connectors; coordinated with and complying with requirements of Section 260513 "Medium-Voltage Cables." Bushings shall be one-piece units, with ampere and BIL ratings the same as connectors.
2. Bushing inserts[ **and feed-through inserts**]:
  - a. Conform to the requirements of IEEE 386.
  - b. Rated at 200 A, with voltage class matching connectors. Provide a parking stand near each bushing well. Parking stands shall be equipped with insulated standoff bushings for parking of energized load-break elbow connectors on parking stands.
  - c. Provide insulated protective caps for insulating and sealing out moisture from unused bushing inserts and insulated standoff bushings.
3. Bushing wells configured for loop-feed application.
4. Access to liquid-immersed fuses.
5. Dead-front surge arresters.
6. Tap-changer operator.
7. Load-Break Switch:
  - a. Radial-feed, liquid-immersed type with voltage class and BIL matching that of separable connectors, with a continuous current rating and load-break rating of 200 amperes, and a make-and-latch rating of 12 kA rms symmetrical.
8. Ground pad.

E. Low-Voltage Section:

1. Bushings with spade terminals drilled for terminating the number of conductors indicated on the Drawings, and the lugs that comply with requirements of Section 260519 "Low-Voltage Electrical Power Conductors and Cables."

F. Capacities and Characteristics:

1. Power Rating (kVA): 400 & 500 kVA.
2. Voltage Ratings: 13.2.k V - 208Y/120 & 480Y/277 V.
3. Taps: Comply with IEEE C57.12.26 requirements.
4. Transformer BIL (kV): Comply with IEEE C57.12.26 requirements.
5. Minimum Tested Impedance (Percent at 85 deg C): 5.75.
6. K-factor: 1 complying with UL 1562.
7. Comply with FM Global Class No. 3990.
8. Comply with UL listing requirements for combination classification and listing for transformer and less-flammable insulating liquid.

G. Transformer Accessories:

1. Drain and filter connection.
2. Filling and top filter press connections.
3. Pressure-vacuum gauge.
4. Dial-type analog thermometer with alarm contacts.
5. Magnetic liquid level indicator with high and low alarm contacts.
6. Automatically resetting pressure-relief device. Device flow shall be as recommended by manufacturer.
7. Stainless-steel ground connection pads.
8. Machine-engraved nameplate, made of anodized aluminum or stainless steel.
9. Sudden pressure relay for remote alarm or trip when internal transformer pressure rises at field-set rate. Provide without seal-in delay.

## 2.4 SERVICE CONDITIONS

- A. Transformers shall be suitable for operation under service conditions specified as usual service conditions in IEEE C57.12.00:
1. Operation above rated voltage or below rated frequency.
  2. Exposure to fumes, vapors, or dust.
  3. Exposure to seismic shock or to abnormal vibration, shock, or tilting.
  4. Exposure to excessively high or low temperatures.
  5. Unusual transportation or storage conditions.

## 2.5 CONTROL NETWORK

- A. Controllers: Support serial MS/TP and Ethernet IP communications, and able to communicate directly via RS-485 serial networks and Ethernet 10Base-T networks as a native device.

## 2.6 WARNING LABELS AND SIGNS

- A. Comply with requirements for labels and signs specified in Section 260553 "Identification for Electrical Systems."
1. High-Voltage Warning Label: Provide self-adhesive warning signs on outside of high-voltage compartment door(s). Sign legend shall be "DANGER HIGH VOLTAGE" printed in two lines of nominal 2-inch-high letters. The word "DANGER" shall be in white letters on a red background and the words "HIGH VOLTAGE" shall be in black letters on a white background.
  2. Arc Flash Warning Label: Provide self-adhesive warning signs on outside of high-voltage compartment door(s), warning of potential electrical arc flash hazards and appropriate personal protective equipment required.

## 2.7 SOURCE QUALITY CONTROL

- A. Provide manufacturer's certificate that the transformer design tests comply with IEEE C57.12.90.

1. Perform the following factory-certified routine tests on each transformer for this Project:
  - a. Resistance.
  - b. Turns ratio, polarity, and phase relation.
  - c. Transformer no-load losses and excitation current at 100 percent of ratings.
  - d. Transformer impedance voltage and load loss.
  - e. Operation of all devices.
  - f. Lightning impulse.
  - g. Low frequency.
  - h. Leak.
  - i. Transformer no-load losses and excitation current at 110 percent of ratings.
  - j. Insulation power factor.
  - k. Applied potential, except that this test is not required for single-phase transformers or for three-phase Y-Y-connected transformers.
  - l. Induced potential.
  - m. Resistance measurements of all windings on rated voltage connection and at tap extreme connections.
  - n. Ratios on rated voltage connection and at tap extreme connections.
  - o. Polarity and phase relation on rated voltage connection.
  - p. No-load loss at rated voltage on rated voltage connection.
  - q. Exciting current at rated voltage on rated voltage connection.
  - r. Impedance.

### PART 3 - EXECUTION

#### 3.1 EXAMINATION

- A. Not used.

END OF SECTION 261219

SEE MATCHLINE - DWG. E-101B

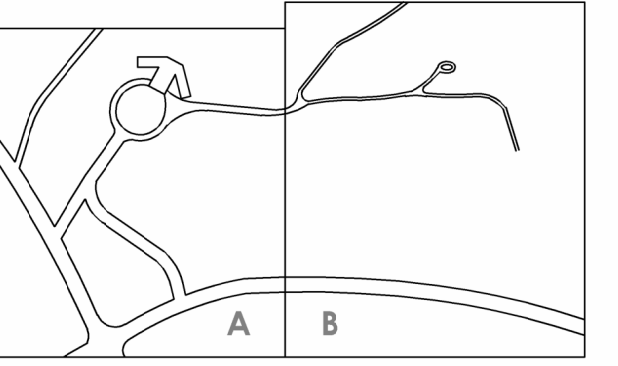

PRE-PURCHASE SITE PLAN #1

OV CF

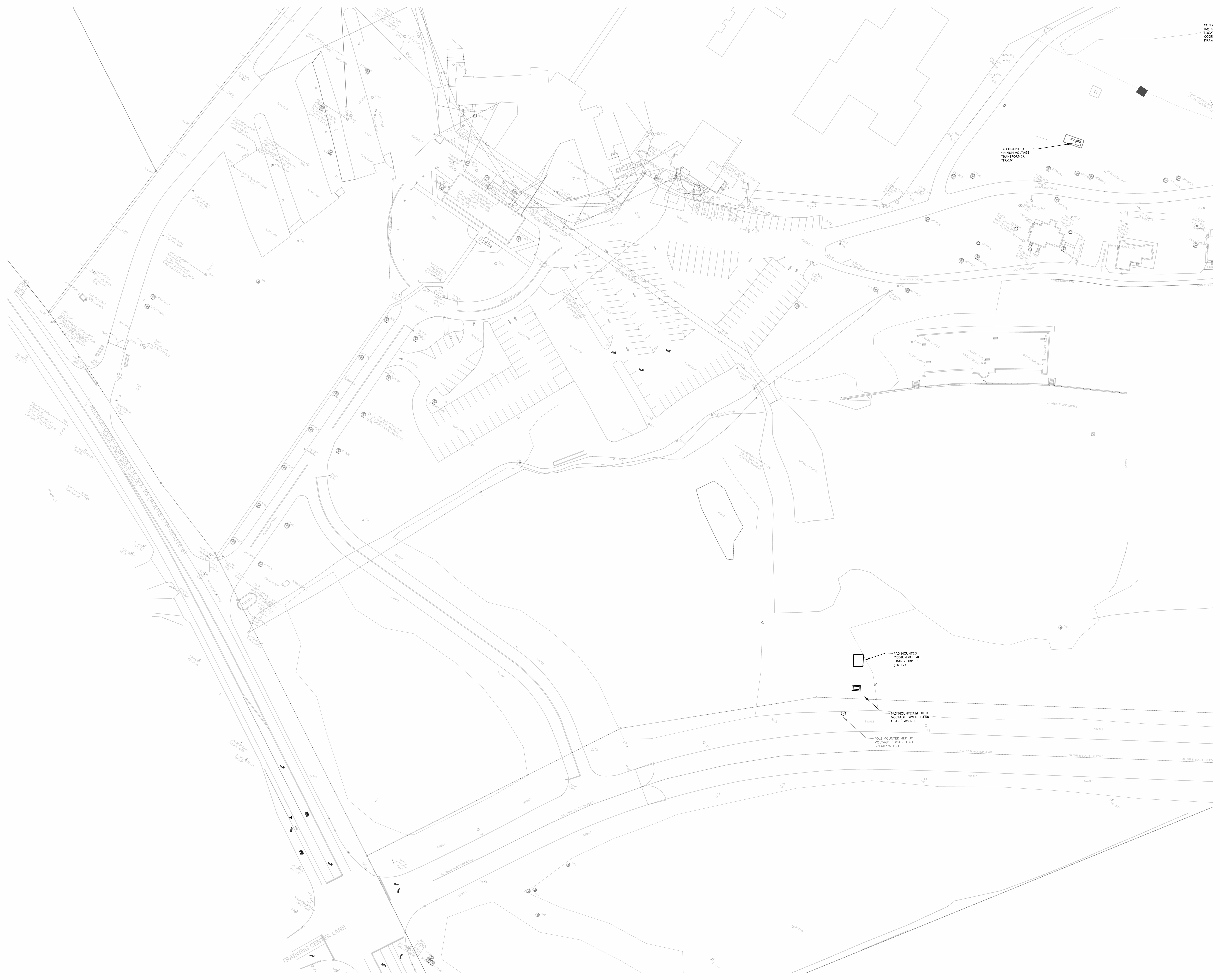

COND  
DASH  
LOCK  
DOOR  
DOOR  
DRAM

PAD MOUNTED  
MEDIUM VOLTAGE  
TRANSFORMER  
TR-16

PAD MOUNTED  
MEDIUM VOLTAGE  
TRANSFORMER  
TR-17

PAD MOUNTED MEDIUM  
VOLTAGE SWITCHGEAR  
GEAR SWGR-1

SOLE MOUNTED MEDIUM  
VOLTAGE 100A LOAD  
BREAK SWITCH

0 20' 40' 80'  
Scale: 1" = 40'-0"



JPM/JM 20/06/18 01:00 PM PRE-PURCHASE SITE PLAN #1 DWG. E-101B

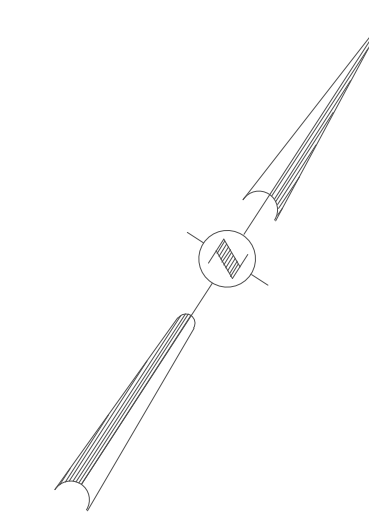

SEE MATCHLINE - DWG. E-101A

**GENERAL NOTES:**

1. PRE-PURCHASE LONG LEAD MEDIUM VOLTAGE EQUIPMENT. EQUIPMENT IS TO BE PURCHASED BY OWNER.
2. UPON DELIVERY EQUIPMENT IS TO BE ACCEPTED BY THE B1 CONTRACTOR AND SHALL BE INSTALLED BY THE B1 CONTRACTOR.
3. AFTER INSTALLATION, THE B1 CONTRACTOR SHALL PERFORM TESTING AS DIRECTED IN THE SPECIFICATIONS.

**PRE-PURCHASE EQUIPMENT SCHEDULE**

EQUIPMENT NAME	DESCRIPTION	Manufacturer	REMARKS
GOAB	GROUP OPERATED LOAD AIR BREAK SWITCH (GOAB)	SIEMENS CAT No. 983VF-45A	LOAD BREAK SWITCH SHALL BE APPROVED FOR USE ON O&S MEDIUM VOLTAGE DISTRIBUTION SYSTEM
SWGR-1	MEDIUM VOLTAGE PAD MOUNTED SWITCHGEAR	ABB CONTROL, INC. EATON CORPORATION SAC ELECTRIC COMPANY SIEMENS ENERGY & AUTOMATION, INC.	SWITCHGEAR SHALL HAVE PROVISIONS FOR ONE INPUT FUSED SWITCH AND TWO OUTPUT SWITCHES. OUTPUT SWITCHES SHALL BE PROVIDED WITH KEY INTERLOCK TO PREVENT BOTH SWITCHES FROM BEING CLOSED AT THE SAME TIME. FEEDER BREAKERS F1 AND F2 ARE PROTECTED BY A SCHWEITZER 381 RELAY SET TO LIMIT CURRENT 225A.
TR-15	400kVA 13.208/120V PAD MOUNTED LIQUID FILLED TRANSFORMER	EATON CORPORATION SIEMENS ENERGY & AUTOMATION, INC.	MEDIUM VOLTAGE TRANSFORMERS ARE TO BE PROVIDED WITH INTERNAL DISCONNECT SWITCHES
	400kVA 13.2480/277V PAD MOUNTED LIQUID FILLED TRANSFORMER	EATON CORPORATION SIEMENS ENERGY & AUTOMATION, INC.	MEDIUM VOLTAGE TRANSFORMERS ARE TO BE PROVIDED WITH INTERNAL DISCONNECT SWITCHES
	500kVA 13.2480/277V PAD MOUNTED LIQUID FILLED TRANSFORMER	EATON CORPORATION SIEMENS ENERGY & AUTOMATION, INC.	MEDIUM VOLTAGE TRANSFORMERS ARE TO BE PROVIDED WITH INTERNAL DISCONNECT SWITCHES

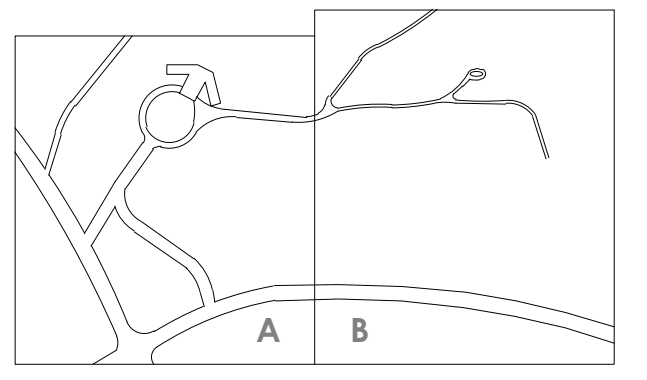

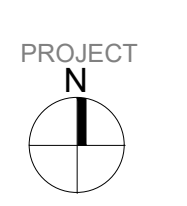
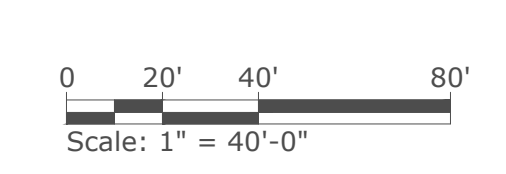

**PRE-PURCHASE SITE PLAN #2**

OV	CF
<b>E-2</b>	



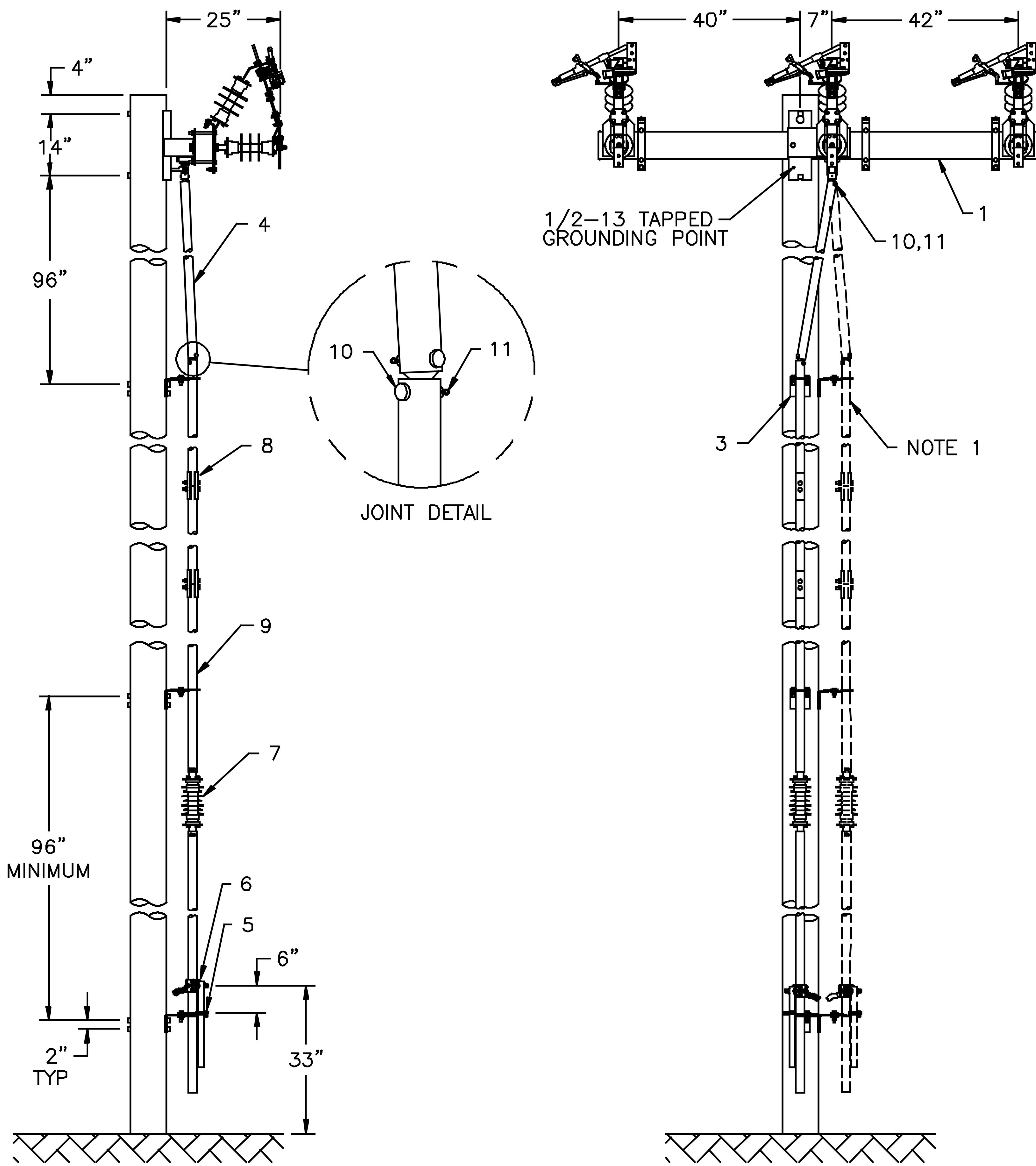



- NOTES:
1. OPERATING MECHANISM MAY BE MOVED TO THE RIGHT QUADRANT OF THE POLE IF DESIRED.
  2. INSULATOR ASSEMBLY MAY BE MOVED UP TO THE NEXT JOINT IN THE OPERATING PIPE IF DESIRED.

RATING DATA	
CAT. NO.	963VF-45A
INTERRUPTING, AMPS	600
MAXIMUM kV	25
kV BIL	150
CONTINUOUS , AMPS	900
MOMENTARY, AMPS	40,000
SWITCH WEIGHT	265 LBS

QTY	DESCRIPTION	QTY	DESCRIPTION
1	VEC4100	17	INSTALLATION/CHECKOUT INSTRUCTIONS
1	B-963VF-A	16	SWITCH UNIT DRAWING
1	B-963VF-45A	15	VECTOR ASSEMBLY DRAWING

QTY	DESCRIPTION	QTY	DESCRIPTION
1	6311-02	14	CRATE
1	4762	13	HARDWARE BOX
1	2822-07	12	CRATING HARDWARE

QTY	DESCRIPTION	QTY	DESCRIPTION
2	8349	11	SS COTTER PIN
2	5116-02	10	GS PIN
4	5106-07	9	PIPE, 7'
2	2825	8	COUPLING ASSEMBLY
1	2645-06	7	INSULATOR ASSEMBLY SILICONE
1	2493	6	HANDLE ASSEMBLY
1	2492-03	5	LOCK SEGMENT ASSEMBLY
1	2481-04	4	U-JOINT ASSEMBLY
2	2270	3	PIPE GUIDE ASSEMBLY

QTY	DESCRIPTION	QTY	DESCRIPTION
1	2820-01	2	NAMEPLATE GROUP
1	963VF-A	1	SWITCH UNIT

QTY	PART NO.	ITEM	MATERIAL	DESCRIPTION
				<b>SIEMENS</b>
				<b>VECTOR ASSEMBLY</b>
				<b>DO NOT SCALE</b>
				<b>B- 963VF-45A</b>

NO.	DATE	DESCRIPTION	BY	APP.	PROPRIETARY: THE INFORMATION CONTAINED IN THIS DRAWING IS THE PROPERTY OF SIEMENS ENERGY, INC. ANY REPRODUCTION WITHOUT THE WRITTEN CONSENT OF SIEMENS ENERGY, INC. IS PROHIBITED. EXCEPT THAT THE CUSTOMER MAY MAKE COPIES FOR USE SOLELY IN THE INSTALLATION, MAINTENANCE, AND OPERATION OF PRODUCTS SUPPLIED BY SIEMENS ENERGY, INC. 99 BOLTON SULLIVAN DR. WEBER SPRINGS AR 72643 USA PH 501-362-8296
A	4/18/12	ADDED 265 LBS SWITCH WEIGHT	DD	AR	

Project Key

REVISIONS

Description	Date

Project Title  
 NEW YORK STATE  
**Office of Mental Health**  
**MID-HUDSON FORENSIC PSYCHIATRIC CENTER**

**FORENSIC REPLACEMENT HOSPITAL NO. 60 SITE READINESS PRE-PURCHASE PACKAGE #1 CR #16**

Phase  
 100% CD RE-SUBMISSION  
**GOAB SWITCH**

Drawn By: OV  
 Checked By: CF  
 Date: 11/03/2023  
 DASNY Project No: 359000  
 Consultant Project No: 3020829/792.01  
 Drawing Number

**SKE-1**

OMH/DASNY  
MID HUDSON FORENSIC  
PSYCHIATRIC REPLACEMENT HOSPITAL  
Electrical Equipment Pre-Purchase

November 9, 2023  
100% CD Resubmission  
DASNY #359000

## **Reference Documents**

### **Bid Package #1 Electrical Site Plans**

THESE DOCUMENTS CONTAIN POTENTIALLY SENSITIVE INFORMATION WHICH IS INTEND FOR THE USE OF THE PUBLIC AND THE INFORMATION SHOULD BE PROTECTED FROM DISCLOSURE TO OTHERS.

Consultants:  
**stv and ar**  
 A joint venture  
 225 Park Avenue South | New York, NY 10003  
 T: 212.777.4600 | F: 212.625.9237 | www.stvarch.com  
 505 Franklin Street | Buffalo, NY 14202  
 T: 716.883.5566 | F: 716.883.5569

**JFK&M** JFK&M Engineers, LLP  
 124 West 57th Street, 22nd floor  
 New York, NY 10019  
 212.752.8730 | 212.675.1999 fax

**KSE** KS Engineers PC  
 22 Boulevard Park, Suite 300  
 Newark, NJ 10007  
 973.623.2999

**MATRIXNEWORLD** Matrix New World Engineering  
 28 Columbia Turnpike, 2nd floor  
 Florham Park, NJ 07932  
 973.345.1800 | 973.345.1918 fax

**PATRIOT** Patriot Design & Consulting  
 1300 East 1st Avenue  
 Rochester, NY 14622  
 585.448.6888

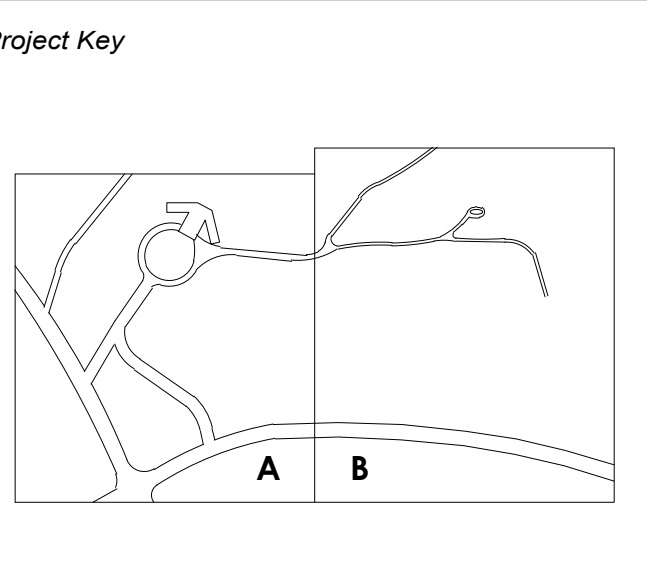

REVISIONS	Description	Date

**NEW YORK STATE** **Office of Mental Health**

## MID-HUDSON FORENSIC PSYCHIATRIC CENTER

### FORENSIC REPLACEMENT HOSPITAL NO. 60 SITE READINESS PACKAGE #1 CR #16

Phase: 100% CD RE-SUBMISSION

## ELECTRICAL SITE UTILITIES PLAN #1

Drawn By: OV | Checked By: CF | Date: 11/03/2023  
 Seal & Signature | DASNY Project No: 359000  
 Consultant Project No: 3020829/792.01  
 Drawing Number

**E-101A**

SEE MATCHLINE - DWG. E-101B



- ELECTRICAL NOTES**
- UTILITY POLE ACROSS THE STREET, WITH O&R SERVICE FEEDER BY ORANGE & ROCKLAND UTILITIES.
  - ORANGE & ROCKLAND FEEDER EXTENDED FROM ACROSS THE STREET TO NHPIC PROPERTY BY O&R.
  - CONTRACTOR TO PROVIDE POLE ON NHPIC PROPERTY. CONTRACTOR SHALL INSTALL ORANGE & ROCKLAND PRIMARY ELECTRIC RETER. THE RETER WILL BE FURNISHED ON R.
  - OVERHEAD UTILITY CONDUCTORS CONSISTING OF 3 - #4/0 (MU105, EPR) PROVIDED BY "BP-1 CONTRACTOR".
  - POLE INSTALLED ON NHPIC PROPERTY BY CONTRACTOR. THIS POLE WILL INCLUDE A GROUP OPERATED AIR BREAK SWITCH (O&R) REFER TO DRAWING E-500. THE SWITCH WILL BE PRE-PURCHASED FOR INSTALLATION ON THE POLE BY THE BP-1 CONTRACTOR. THE POLE IS TO BE FURNISHED BY THE "BP-1 CONTRACTOR".
  - NEW NHPIC OWNED AND OPERATED INCOMING SERVICE SWITCHGEAR. SERVICE SWITCHGEAR WILL BE PRE-PURCHASED AND IS TO BE INSTALLED BY "BP-1 CONTRACTOR". SERVICE SWITCHGEAR WILL INCLUDE THE FOLLOWING:
    - 6.A. METAL CLAD 35KV CLASS SWITCHGEAR COMPLYING WITH ALL APPLICABLE O&R REGULATIONS
    - 6.B. MAIN HORIZONTAL BUS BARR
    - 6.C. MAIN INCOMING CIRCUIT BREAKERS 600A VACUUM BREAKER, WITH A SCHWITZER 351 RELAY & KUKK INTERLOCKS
    - 6.D. TWO 600A LOAD BREAK SWITCHES FOR DISTRIBUTION
    - 6.E. REFER TO DETAIL SHEET E-501 FOR ADDITIONAL INFORMATION.
  - CONCRETE MANHOLE
  - 500 kVA PAD MOUNTED TRANSFORMER PRE-PURCHASED BY OWNER FOR INSTALLATION BY CONTRACTOR.

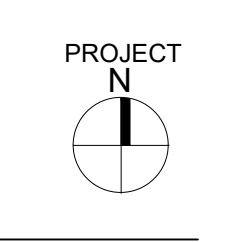
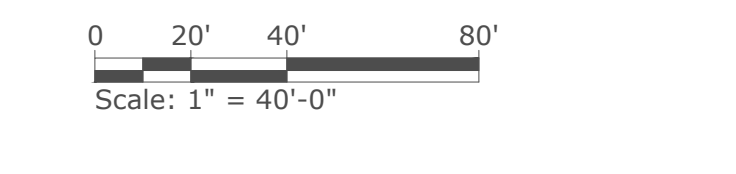

ISSUED FOR REFERENCE ONLY

JFK&M 2023041 E-101A\_BPH1.DWG, Sheet: 11/03/2023 2:50 PM, Orange

THESE DOCUMENTS CONTAIN POTENTIALLY SENSITIVE INFORMATION AND SHALL BE USED FOR THE INTENDED PURPOSE AND THE INFORMATION CONTAINED HEREIN IS NOT TO BE DISSEMINATED TO ANY OTHER PARTY.

CONSULTANTS:  
**stv and ar**  
 A joint venture  
 225 Park Avenue South | New York, NY 10003  
 T: 212.777.4600 | F: 212.529.9237 | www.stvarch.com  
 505 Franklin Street | Buffalo, NY 14202  
 T: 716.883.5566 | F: 716.883.5569 | www.archives.com

**JFK&M** JFK&M Engineers, LLP  
 124 West 31st Street, 32nd Floor  
 New York, NY 10018  
 212.750.8700 | 212.675.1999 fax

**KSE** KS Engineers PC  
 2 Boulevard Plaza, Suite 300  
 Newark, NJ 07102  
 973.623.2999

**MATRIXNEWORLD** Matrix New World Engineering  
 28 Columbia Turnpike, 2nd Floor  
 Florham Park, NJ 07932  
 973.340.1800 | 973.340.1818 fax

**PATRIOT** Patriot Design & Consulting  
 1300 East Tenth Avenue  
 Rochester, NY 14622  
 585.446.6666

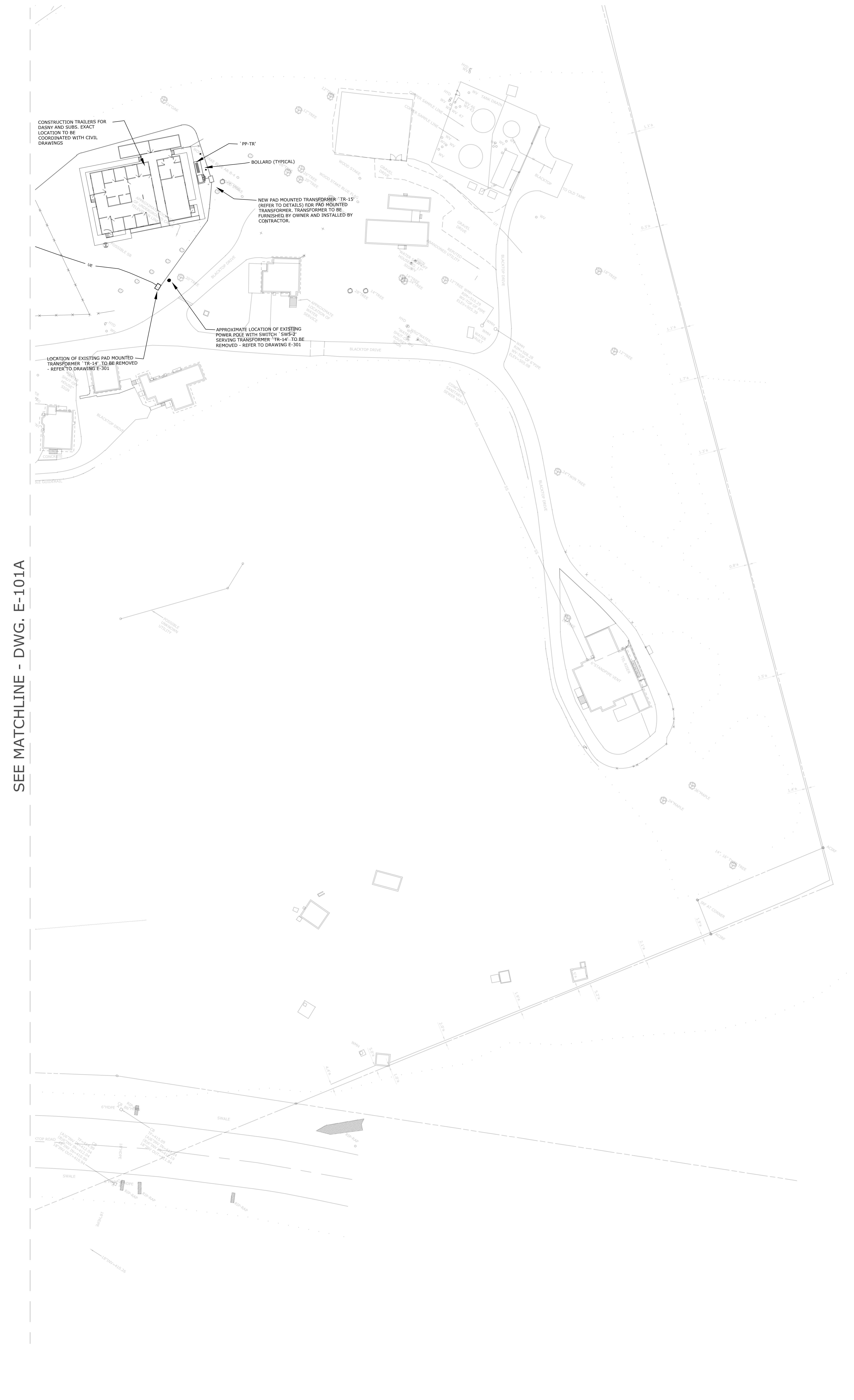
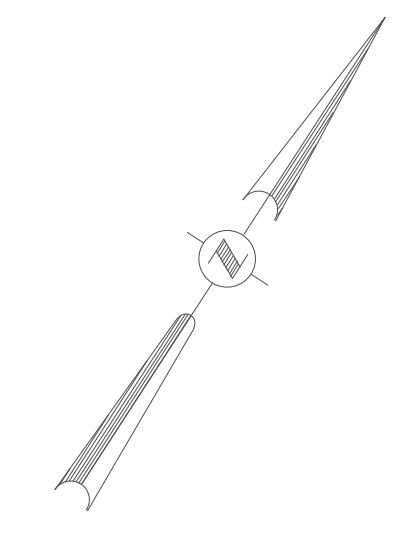

SEE MATCHLINE - DWG. E-101A

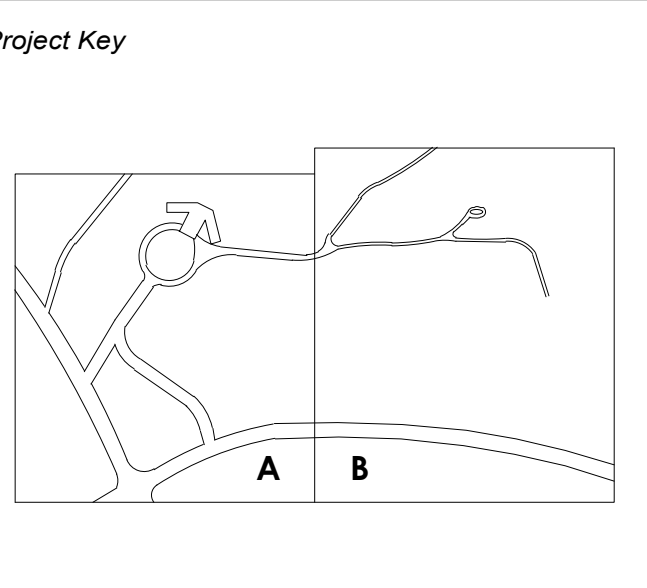

REVISIONS

Description	Date

Project Title

NEW YORK STATE Office of Mental Health

**MID-HUDSON FORENSIC PSYCHIATRIC CENTER**

**FORENSIC REPLACEMENT HOSPITAL NO. 60 SITE READINESS PACKAGE #1 CR #16**

Phase  
 100% CD RE-SUBMISSION

**ELECTRICAL SITE UTILITIES PLAN #2**

Drawn By: OV | Checked By: CF | Date: 11/03/2023  
 DASNY Project No: 359000  
 Consultant Project No: 3020829/792.01  
 Drawing Number: **E-101B**

ISSUED FOR REFERENCE ONLY

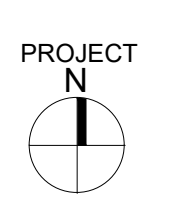
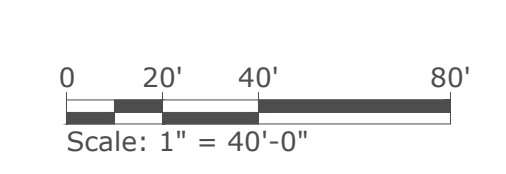

SECTION 261329 – PRE-PURCHASE - MEDIUM-VOLTAGE, PAD-MOUNTED OIL INSULATED SWITCHGEAR

PART 1 - GENERAL

1.1 RELATED DOCUMENTS

- A. Drawings and general provisions of the Contract, including General and Supplementary Conditions and Division 01 Specification Sections, apply to this Section.

1.2 SUMMARY

- A. Section includes dead-front, remotely controlled insulated vacuum load and fault interrupting switchgear.
- B. Switchgear is to be pre-purchased by the Owner (DASNY).

1.3 DEFINITIONS

- A. BIL: Basic Impulse Insulation Level.
- B. Bushing: An insulating structure including a central conductor, or providing a central passage for a conductor, with provision for mounting on a barrier, conducting or otherwise, for insulating the conductor from the barrier and conducting current from one side of the barrier to the other.
- C. Bushing Elbow: An insulated device used to connect insulated conductors to separable insulated connectors on dead-front, pad-mounted switchgear and to provide a fully insulated connection. Also called an "elbow connector."
- D. Bushing Insert: That component of a separable insulated connector that is inserted into a bushing well to complete a dead-front, load break or non-load break, separable insulated connector (bushing).
- E. Bushing Well: A component of a separable insulated connector, either permanently welded or clamped to an enclosure wall or barrier, having a cavity that receives a replaceable component (bushing insert) to complete the separable insulated connector (bushing).
- F. Fault Interrupter: A self-controlled mechanical switching device capable of making, carrying, and automatically interrupting an alternating current. It includes an assembly of control elements to detect overcurrents and control the fault interrupter. A fault interrupter always consists of a switching device, a control unit, and sensors for current and/or voltage sensing.

- G. Hotstick: An insulated stick, usually made of fiberglass, that is used to work energized overhead conductors and operate electrical equipment that is overhead, underground, and compartmentalized.
- H. NETA ATS: Acceptance Testing Specification.
- I. SCADA: Supervisory control and data acquisition.
- J. Way: A three-phase or single-phase circuit connection to the bus that may contain combinations of switches and protective devices or may be a solid bus.
- K. Provide: Furnish and install.
- L. Furnish: Purchase only
- M. Install: Install only.

#### 1.4 ACTION SUBMITTALS

- A. Product Data: For each type of product.
  - 1. Include rated capacities, operating characteristics, and furnished specialties and accessories.
  - 2. Time-current characteristic curves for overcurrent protective devices.
- B. Shop Drawings: For pad-mounted switchgear.
  - 1. Include plans and elevations showing major components and features.
    - a. Include a plan view and cross section of equipment base showing clearances, required workspace, and locations of penetrations for grounding and conduits.
  - 2. Include details of equipment in each way and indicate dimensions, weights, loads, required clearances, and location and size of each field connection.
  - 3. Include single-line diagram.
  - 4. Include list of materials.
  - 5. Include nameplate data.
  - 6. Include control power wiring diagrams.
  - 7. Include battery, charger, and transfer switch ratings.
  - 8. Include copy of nameplate.
  - 9. Switchgear Ratings:
    - a. Voltage.
    - b. Continuous current.
    - c. Short-circuit rating.
    - d. BIL.
  - 10. Design Calculations: Signed and sealed by a qualified professional engineer.

11. Wiring Diagrams: For each switchgear assembly, include the following:

- a. Power, signal, and control wiring.
- b. Schematic diagrams showing connections to remote devices.

#### 1.5 INFORMATIONAL SUBMITTALS

A. Coordination Drawings:

1. Utilities site plan, drawn to scale, showing heavy equipment or truck access paths for maintenance and replacement.

B. Qualification Data: For testing agency.

C. Product Certificates: For pad-mounted switchgear.

1. Switch ratings as listed in IEEE C37.74.
2. Interrupter ratings as listed in IEEE C37.60.
3. Coating system compliance with the IEEE standard listed in "Enclosure" Article.

D. Source quality-control reports.

E. Field quality-control reports.

#### 1.6 CLOSEOUT SUBMITTALS

A. Operation and Maintenance Data: For switchgear and switchgear components to include in emergency, operation, and maintenance manuals.

1. In addition to items specified in Section 017823 "Operation and Maintenance Data," include the following:
  - a. Manufacturer's written instructions for testing and adjusting overcurrent protective devices.
  - b. Time-current curves, including selectable ranges for each type of overcurrent protective device.
  - c. Record as-left set points of adjustable devices.

#### 1.7 QUALITY ASSURANCE

A. Testing Agency Qualifications: Member company of NETA.

1. Testing Agency's Field Supervisor: Certified by NETA to supervise on-site testing.

## PART 2 - PRODUCTS

### 2.1 MANUFACTURERS – SUBJECT TO APPROVAL BY ORANGE AND ROCKLAND UTILITIES

1. Eaton Corporation; Cutler-Hammer Products.  
**Model PSAE-1A1-X-E**
2. Siemens Energy & Automation, Inc.

### 2.2 SYSTEM DESCRIPTION

- A. Manufactured Unit: Pad-mounted switchgear, designed for application in impedance-grounded underground distribution systems.
- B. Electrical Components, Devices, and Accessories: Listed and labeled as defined in NFPA 70, by a qualified testing agency, and marked for intended location and application.
- C. Comply with IEEE C2.
- D. Comply with IEEE C37.74.

### 2.3 PERFORMANCE REQUIREMENTS

- A. Service Conditions:
  1. Switchgear shall be suitable for operation under service conditions specified as usual service conditions in IEEE C37.20.3

### 2.4 RATINGS

- A. Switchgear is applied to a nominal 13.2kV (L-L) medium-voltage electrical power system. Minimum ratings of the switchgear shall be as follows:
  1. Rated Maximum Voltage and Rated BIL: ~~25~~ **15** kV and ~~125~~ **95** kV BIL.
  2. Continuous and Load Interrupting Current: 600 A.
  3. Short-Time and Short-Circuit Interrupting Current: 16 kA rms Sym.

### 2.5 ENCLOSURE

- A. Weatherproof enclosure with an integral skid mounting frame, designed for mounting on a concrete pad, suitable to allow skidding or rolling of the switchgear in any direction, and with provision for anchoring the frame to the pad.



- B. Enclosure Integrity: Comply with IEEE C57.12.28 for compartmentalized enclosures that contain energized electrical equipment in excess of 600 V that may be exposed to the public.
- C. Corrosion Protection: Fabricate the support frame, enclosure base, and the enclosure from stainless steel, ASTM A 167, Type 304 or 304L. Enclosure coating system shall be factory applied, meeting the requirements of IEEE C57.12.28, standard color.

## 2.6 CONSTRUCTION

- A. Dead-front, ~~front and rear~~ **Dual-side front** access switchgear.
  - 1. **Main on Front 1**
  - 2. **Feeders on Front 2**
- B. Each disconnect switch in switched ways shall be in a sealed, dielectric filled stainless-steel tank, factory-filled with ~~mineral oil or~~ less-flammable, high-firepoint fluid.
  - 1. ~~Mineral Oil: Comply with ASTM D 3487, Type II, and tested for compliance with ASTM D 117. Provide enclosure with level gauge to monitor the dielectric level; automatic pressure relief valve; and fill, drain, and sampling valves.~~
  - 2. Less-flammable, high-firepoint fluid shall comply with ASTM D 6871 and IEC 61099. The temperature rating of the fluid shall be satisfactory for ambient air temperatures of minus 30 deg C and plus 40 deg C. Provide enclosure with level gage to monitor the dielectric level; automatic pressure relief valve; and fill, drain, and sampling valves.
- C. Construct switchgear assembly with switched ways that have front-accessible terminations for cables entering from below and with manual operating provisions with a lineman's hotstick.
- D. ~~Trapped Key Interlocks: Kirk key interlock system using a dowel pin design having no openings. Brass housing and 316 stainless steel key and lock bolts.~~
- E. Viewing Windows: For each switch, located adjacent to manual operating devices, and positioned to show switch contact position.
- F. Grounding: Provision to make grounding cable and wire connections at each way.

## 2.7 SWITCHED WAYS

- A. Source Switch Ways: Non-fused, hotstick operated, ganged vacuum load interrupter switches, in series with a visible-break disconnect switch.

**Each source and feeder way to include SEL-751 multifunction protective relay, with C100 accuracy under oil current transformers, with 5A secondary current. Source to include under oil voltage transformers. Relay settings provided by others.**

- 1. Rated Continuous Current and Load Switching Current: 600 A.
- 2. Vacuum Load Interrupter:
  - a. With 24 V dc motor operators to open or close the load interrupter.

- b. Trip-free switch mechanism. Closing the switch shall be independent of the speed of the operating handle.
  3. Visible-Break Disconnect Switch: Two positions, with open and closed positions. The switch shall be mechanically interlocked so that the vacuum interrupter opens and closes first.
    - a. Switch position indicator, clearly labeled.
    - b. Padlocking and tagging provisions.
- B. Fault Interrupting Switched Ways: Non-fused, hotstick-operated, ganged vacuum fault interrupter switches, in series with a visible-break disconnect. With internally mounted current transformers and electronic overcurrent sensing for three-phase ganged tripping of the interrupter. Comply with IEEE C37.60.
  1. Rated Continuous Current and Load Switching Current: 600 A.
  2. Vacuum Fault Interrupter:
    - a. Operated by a motor-charged stored energy mechanism, with provision to manually charge the mechanism. Charging motors shall operate at 24 V ~~ac~~ **dc**.
    - b. Auxiliary Switches: Provide two auxiliary switches, each with field-selectable NC or NO switch position, for connection of remote indication of the position of the switched way. The switches shall be rated at 15 A, 120 V ac, and 1 A, 120 V dc.
    - c. Trip-free switch mechanism when manually operated. Closing the switch shall be independent of the speed of the operating handle.
    - d. Single operating handle and a clearly labeled switch position indicator; open, closed, tripped.
    - e. Operations Counters: Mechanical type, linked to the operating handle of each switched way.
    - f. Padlocking and tagging provisions.
  3. Visible-Break Disconnect Switch: Two positions, with open and closed positions. The switch shall be mechanically interlocked so that the switch cannot be operated unless the vacuum fault interrupter is open.
    - a. Switch position indicator, clearly labeled.
    - b. Padlocking and tagging provisions.
- C. Controls:
  1. Motor Actuators: "Open," "close," and "stop" push buttons.
  2. Switch Status LEDs: "Open" and "closed" lights. Show status of disconnect switch using its auxiliary contact.
  3. Motor Actuator Process LEDs: "Opening" and "closing" lights indicating that the selected motor is operating the switch.
  4. Power Switch: "On" and "off" toggle switch and circuit protector, to disconnect the dc supply to its motor and provide overload and short-circuit protection.
  5. 120 V ac LED to display battery system power level.
  6. Battery voltage meter to show battery condition.

7. Local and Remote Selector: In the "local" position remote operation of the switches is disabled and is possible only under the control of switchgear-mounted push buttons.

- D. Overcurrent and Control Relays: **SEL-751 Microprocessor-based multi-function protective relay.** ~~Field adjustable microprocessor electronic relays in each phase at indicated locations.~~ Provide for current adjustment from 0 to 600 A.

1. Device Functions: 51/50, 51N/50N, or 51G/50G according to IEEE C37.2.

## 2.8 POWER SUPPLY

- A. The power supply for instrumentation, communications, and switch operations shall be from a potential transformer installed as part of the switchgear.
- B. The power supply for instrumentation, communications, and switch operations shall be from a 24 V dc power supply installed as part of the switchgear with the following characteristics:
  1. An integral power transformer.
  2. An alternate power supply consisting of a 24 V dc uninterruptible power supply with a sealed lead-acid gel-cell maintenance free battery system.
    - a. The battery system shall be sized to meet all power demands, including the operation of all motor-operated switches in the pad-mounted switchgear at least once in a 24-hour period.
  3. An automatic transfer switch to connect the alternate power supply when the primary power supply has failed.

## 2.9 AUTOMATIC SOURCE TRANSFER CONTROLS

- A. An automatic switch control system shall execute manual, ~~automatic source transfer, and~~ **and remote** SCADA operation of the source and fault interrupting switch ways. ~~The source transfer controls shall open an incoming switch way where voltage is lost and close the other incoming switch way if voltage is present.~~ The controls shall include an overcurrent lockout that prevents the closing of a switch way into a system fault.
- B. The control shall have communication port provisions for connection to a multi-mode serial fiber link.

## 2.10 CONTROL NETWORK

- A. Controllers: Support serial MS/TP and Ethernet /~~TCPIF~~ **IP** communications; able to communicate directly via RS-485 serial networks and Ethernet 10Base-T networks as a native device. **SEL-2725 Ethernet switch furnished and installed by switchgear manufacturer.**

## 2.11 BUSHINGS

- A. Separable insulated connectors shall be used to connect primary cable. Comply with requirements in Section 260573 "Medium-Voltage Cables."
  - 1. Bushings: One-piece, 600 A, BIL ratings the same as the connectors. Comply with IEEE 386.
  - 2. Supply a standoff bracket or parking stand for each bushing, mounted horizontally adjacent to each bushing.

## 2.12 SURGE ARRESTERS

- A. Distribution class; metal-oxide-varistor type, fully shielded, separable elbow type, suitable for plugging into the inserts. Comply with IEEE C62.11 and IEEE 386.
  - 1. Nominal System Line-to-Line Voltage: 13.2 kV rms.
  - 2. Maximum Continuous Operating Voltage: 15 kV rms.
  - 3. Duty-Cycle Voltage: 13.2 kV rms.

## 2.13 WARNING LABELS AND SIGNS

- A. Comply with requirements in Section 260553 "Identification for Electrical Systems" for labels and signs.
  - 1. High-Voltage Warning Label: Self-adhesive warning signs on the outside of the high-voltage compartment door(s). Sign legend shall be "DANGER HIGH VOLTAGE" printed in two lines of nominal 2-inch (50 mm) high letters. The word "DANGER" shall be in white letters on a red background and the words "HIGH VOLTAGE" shall be in black letters on a white background.
  - 2. Arc-Flash Warning Label: Self-adhesive warning signs on the outside of the high-voltage compartment door(s), warning of potential electrical arc-flash hazards and appropriate personal protective equipment required.

## 2.14 SOURCE QUALITY CONTROL

- A. Factory Tests: Comply with requirements in IEEE C37.60 and IEEE C37.74 for testing procedures.
  - 1. Circuit Resistance Test: Verify that switchgear contacts have been properly aligned and current transfer points have been properly assembled.
  - 2. Power-frequency dry withstand voltage test.
  - 3. Dielectric withstand test; one-minute dry power-frequency.
  - 4. Calibrate overcurrent devices for conformance to published time-current characteristic curves.
  - 5. Sealed Tank Leak Test:

- a. Comply with IEC 62271-1 for test procedure for switchgear using SF6.
  - b. The test procedure for vacuum switchgear shall be as follows:
    - 1) Each vacuum tube shall be identified by its serial number. Its vacuum pressure level shall be tested by the manufacturer of the vacuum interrupter. Document the test results.
    - 2) After assembly of the switchgear way, test the vacuum pressure level of the vacuum tubes by the routine dielectric test across the open contacts. The test voltage shall be stated by the manufacturer. The dielectric test shall be carried out after the mechanical routine test.
6. Operating tests shall verify the following:
- a. Switch position indicators and contacts are in the correct position for both the open and closed positions.
  - b. Insulating medium quantity indicator (if provided) is functioning properly.
  - c. Circuit configuration is shown correctly.
  - d. Mechanical interlocks are in place and operative.
  - e. Position and polarity of current transformers meets requirements.
  - f. Control, secondary wiring, and accessory devices are connected correctly.
  - g. Devices and relays actually operate as intended. Circuits for which operation is not feasible shall be checked for continuity.

### PART 3 - EXECUTION

- A. Deliver ~~transformers~~ **switchgear** to job site. **Off-load and handling to be provided by others.**  
~~and offload at location as directed on site.~~

END OF SECTION 261329