



ADDENDUM NO.: 2

Description: Furnish and Deliver Medium Voltage Pad-Mounted Switch Gear

Project: 3590009999

Bid Due Date: January 19, 2024

Specifics of the Addendum: Respond to questions received during the Request for Information period.

Location: OMH – Mid-Hudson PC

Please see the attached drawings with single line diagram below.

DRAWING NOTES

- 1. NEW POLE INSULATED CABLE UTILITY (AFTER POLE) TO BE PROVIDED BY EPC CONTRACTOR. ALL SERVICES TO BE PROVIDED BY EPC CONTRACTOR.
- 2. NEW POLE INSULATED CABLE (WITH 7000 PSI STRENGTH) TO BE PROVIDED BY CUSTOMER. THE ABILITY TO DISCONNECT THE SERVICE WITHOUT OAR PROCEEDINGS CONTRACTORS WILL BE PROVIDED BY CONTRACTOR. DIMENSIONS BY EPC CONTRACTOR.
- 3. NEW POLE INSULATED UTILITY (AFTER POLE) TO BE PROVIDED BY EPC CONTRACTOR. ALL SERVICES TO BE PROVIDED BY EPC CONTRACTOR. DIMENSIONS BY EPC CONTRACTOR.
- 4. NEW POLE INSULATED UTILITY (AFTER POLE) TO BE PROVIDED BY EPC CONTRACTOR. ALL SERVICES TO BE PROVIDED BY EPC CONTRACTOR. DIMENSIONS BY EPC CONTRACTOR.
- 5. NEW SECONDARY DISCONNECT SWITCH AND FUSES, 400V, 3-PHASE.
- 6. THE SERVICE LINES BY THE MAIN TOWER, 400V, 3-PHASE, SHALL BE TRANSFERRED TO THE NEW SYSTEM UNDER EPC CONTRACT.
- 7. NOT USED.
- 8. CONCRETE MANHOLE.
- 9. ALL ELECTRICAL FIBERS (OR) OTHER FIBER CABLES.
- 10. FIBER OPTIC IN 2" UNDERGROUND DUCTS IN 4" CONDUIT.
- 11. ALL WORK AND EQUIPMENT INDICATED IS NEW UNLESS OTHERWISE NOTED BY EPC CONTRACTOR UNLESS OTHERWISE NOTED.

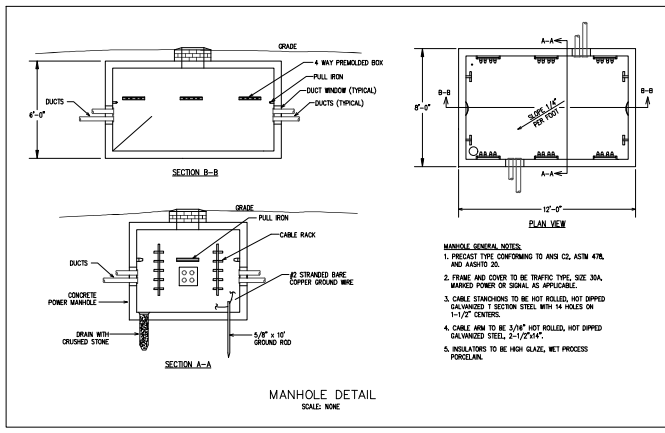
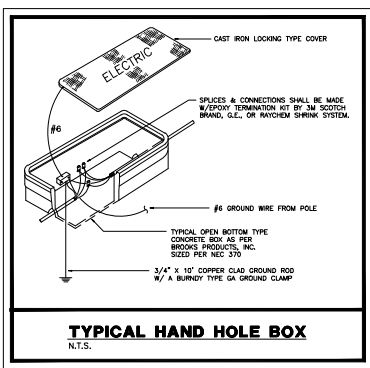
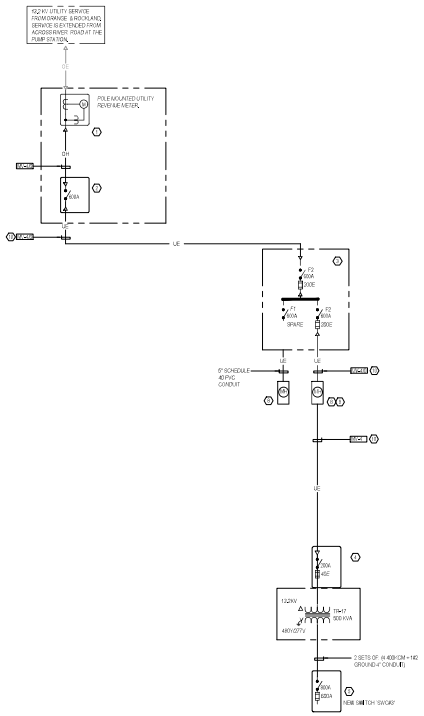

Project File

REVISIONS

No.	Description	Date

Project File

Phase BID DOCUMENTS

ELECTRICAL SITE UTILITY ONE LINE DRAWING

Drawn By: CP | Checked By: | Date: 12/11/2023
DWG. # 3559000

PROJECT NO. P. 3020202/192.01
Drawing Number:



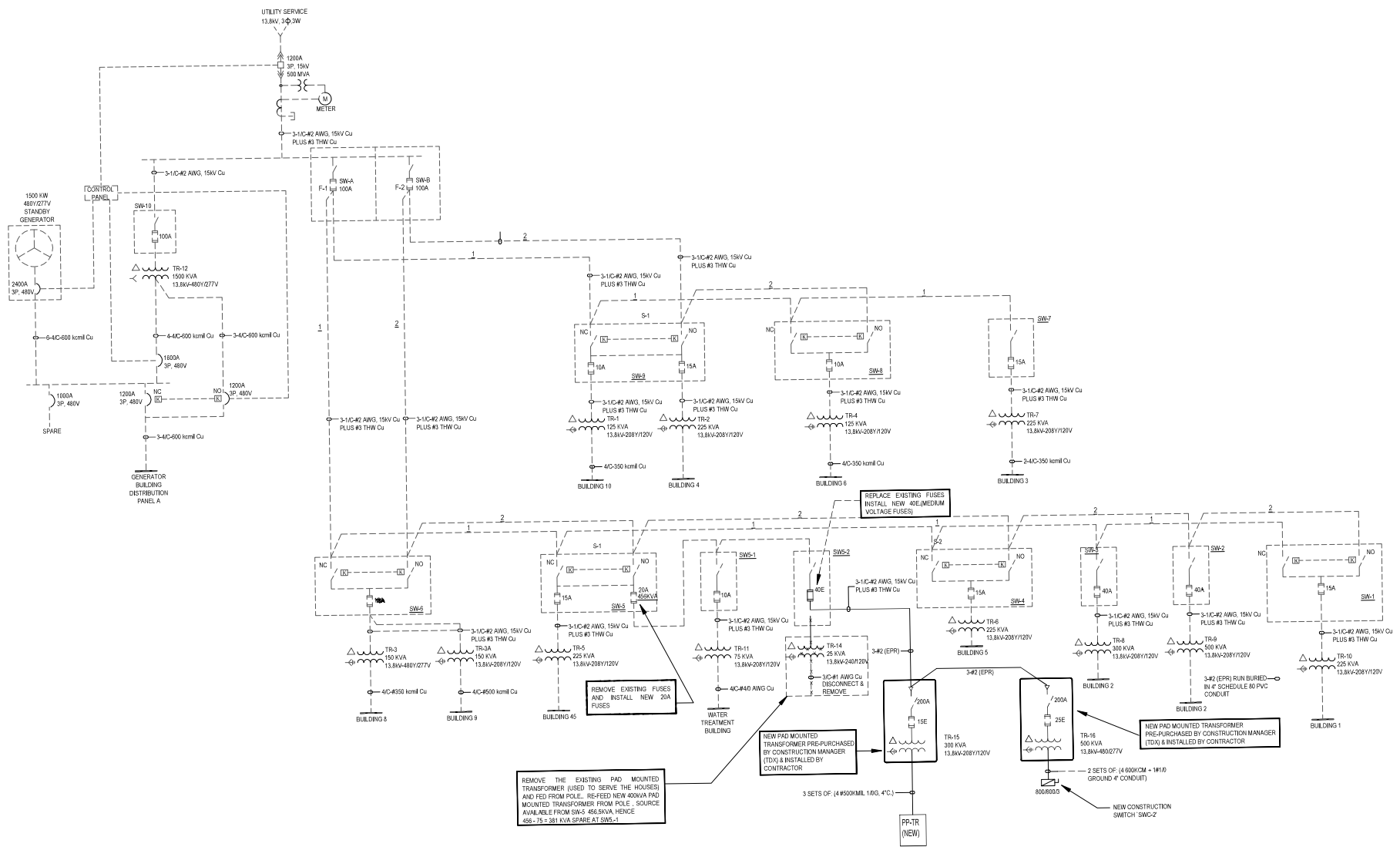

ELECTRICAL SINGLE LINE DIAGRAM
 N.T.S.

DISTRIBUTION PANELBOARD SCHEDULE 208Y/120V - 3 PHASE - 4 WIRE + GND

PP-TR	CIRCUIT BREAKER	FEEDER DESIGNATION	LOAD DESCRIPTION	LOAD HP (KW)	FEEDER							
					PHASE LEGS		NEUTRAL	GROUND				
					No.	SIZE	No.	SIZE	No.	SIZE	CONDUIT SIZE	
1200A MAIN BUS	1	800	800	3	SPARE	FOR DASNY TRAILERS	-	-	-	-	-	-
	2	800	800	3	SPARE	FOR CONTRACTOR TRAILERS	-	-	-	-	-	-
	3	100	-	3	-	SPACE	-	-	-	-	-	-
	4	100	-	3	-	SPACE	-	-	-	-	-	-

Project No.

REVISIONS	Description	Date

Project File
Office of Mental Health
MID-HUDSON FORENSIC PSYCHIATRIC CENTER

FORENSIC REPLACEMENT HOSPITAL NO. 60 SITE READINESS PACKAGE #1 CR #16

Phase **BID DOCUMENTS**

ELECTRICAL SINGLE DASNY & SUBS TRAILERS

Drawn By: [] Checked By: [] Date: 12/11/2023
 CV: CF
 Seal & Signature: 359000

Contract Project No: 3020829/92.01
 Drawing Number: **E-301**

