



DASNY

SECTION A



BID NO.:611

PROJECT NAME & LOCATION Lehman College
250 Bedford Park Blvd. W
Bronx, NY 10468

Description: Installation of Sedia Seating Furniture

Bid Open Location: DASNY

515 Broadway, Albany, New

York Bid Open Date: June 22, 2018

Bid Open Time: 2:30 p.m.

Contact: Kristen Costello (518) 257-3119

NOTICE TO BIDDERS

MAIL BIDS EARLY

Sealed bids will be received by DASNY at the above address for the items listed in the attached Bid Breakdown and Schedule. When submitting your bid you must:

1. Prepare your bid on the attached Bid Breakdown and Schedule. Return one signed original of the Bid Breakdown and Schedule
2. If your bid deviates from Specifications, explain such deviations or qualifications on your letterhead, setting forth therein such explanations, and attach them to the Bid Breakdown and Schedule.
3. Submission of a bid constitutes full knowledge and acceptance of all provisions of the Notice to Bidders, all information referenced in the Purchasing General Conditions, Supplemental and Detailed Specifications, the Bid Submission and any Supplemental General Requirements contained herein, as well as any addenda issued in relation to the Invitation for Bids.
4. Each bid shall bear on the outside of the envelope the name of the bidder, address, telephone number and designated as a bid for the following:
DASNY Bid No. 611 - Installation of Sedia Seating
Bid Opening Date: June 22, 2018 @ 2:30PM

Return to:
DASNY
Attn: Purchasing Unit
515 Broadway
Albany, NY 12207-2964



Bid No.: 611

When a sealed bid is placed inside another delivery jacket, the bid delivery jacket must be clearly marked on the outside “**BID ENCLOSED**” and “**ATTENTION: PURCHASING UNIT**”. The Dormitory Authority will not be responsible for receipt of bids which do not comply with these instructions.

5. Mail bid responses early in order for them to be received before the time of the bid opening. **Late bids will be automatically rejected.** Individuals submitting bids in person or by private delivery services should allow sufficient time for processing through building security to assure that the bids are received prior to the deadline for submitting bids. All individuals who plan to attend bid openings will be required to present government-issued picture identification to building security officials and obtain a visitor’s pass prior to attending the bid opening.

6. In accordance with State Finance Law § 139-j and 139-k, this solicitation includes and imposes certain restrictions on communications between Dormitory Authority personnel and an Offerer during this procurement process. Designated contact for this solicitation is: Kristen Costello, Sr. Purchasing Coordinator , at Dormitory Authority – State of New York, 515 Broadway, Albany, NY 12207,(518) 257-3119. Contacts made to other Dormitory Authority Personnel regarding this procurement may disqualify the Offerer and affect future procurements with governmental entities in the State of New York. Please refer to the Authority’s website www.dasny.org for Authority policy and procedures regarding this law, or the NYS office of General Services website www.ogs.ny.gov/BU/PC/ for more information about this law.



Bid No.: 611

If you are not submitting a bid it is requested that you complete and return the lower portion of this form

(Please check all that apply and provide comments in the space provided, if necessary)

We are not Submitting a bid.

We Request removal of our name from the mailing list.

Location of the job site.

Commodity is not carried by our company.

Scope is too large.

Other/Additional Explanation: _____

NAME OF BIDDER: _____

ADDRESS _____

:

Street Telephone

City

State

Zip

Signature of Bidder

Official Title

CLAUSES PURSUANT TO THE OMNIBUS PROCUREMENT ACT OF 1992

It is the policy of New York State to maximize opportunities for the participation of New York State business enterprises, including minority and woman-owned business enterprises as bidders, subcontractors and suppliers on its procurement contracts.

Information on the availability of New York subcontractors and supplies is available from:

Empire State Development
Small Business Division
30 South Pearl Street, 7th Floor
Albany, NY 12207
Phone: (800) 782-8369

A directory of minority and woman-owned business enterprises is available from:

Empire State Development
Division of Minority and Women Business Development
30 South Pearl Street
Albany, NY 12207
Phone: (518) 292-5250

Online Directory: <https://ny.newnycontracts.com/FrontEnd/VendorSearchPublic.asp>

[DASNY maintains a directory of minority and women-owned business enterprises:
http://www.dasny.org/construc/mwsberreg/index.php](http://www.dasny.org/construc/mwsberreg/index.php)

The contractor acknowledges notice that New York State may seek to obtain offset credits from foreign countries as a result of this contract and agrees to cooperate with the State in these efforts.

DASNY encourages the use of recycled Materials in the manufacturing process. To that end, the recycled product must meet the same codes, specifications and standards the non-recycled materials do, including requirements for cost, installation, aesthetics, availability and maintenance.

The Omnibus Procurement Act of 1992 and § 2879 of the NYS Public Authorities Law require that by signing this bid, contractors certify that whenever the total bid amount is greater than \$1 million:

1. The contractor has made reasonable efforts to encourage the participation of New York State Business Enterprises as suppliers and Subcontractors on this project, and has retained the documentation of these efforts to be provided upon request to the State. If the contractor determines that NYS business enterprises are not available to participate on the contract as subcontractors or suppliers, the contractor shall provide a statement indicating the method by which such determination was made. If the contractor does not intend to use subcontractors, contractor shall provide a statement verifying such;
2. The contractor has complied with the Federal Equal Opportunity Act of 1972 (PL 92-261), as amended;
3. The contractor agrees to make reasonable efforts to provide notification to New York State residents of employment opportunities on this project through listing any such positions with the Job Service Division of the New York State Department of Labor, or providing such notification in such manner as is consistent with existing collective bargaining contracts or agreements. The contractor agrees to document these efforts and to provide said documentation to the State upon request;

DASNY is required by law to notify the NYS Department of Economic Development of any procurement contract for one million dollars or more that is to be awarded to an out-of-state vendor. This notice must be done simultaneous to the notification of award provided to the vendor. A purchase order or contract cannot be issued until fifteen (15) days after such notification is provided.



DASNY

GENERAL SPECIFICATIONS

- (1) The enclosed Purchasing General Conditions are hereby incorporated by reference. Submission of a bid response shall constitute acceptance of such conditions. Any exceptions/clarifications/qualifications to these conditions or other specifications and/or requirements contained herein must be clearly stated in the bid response and, depending upon the nature of such, may be grounds for rejection of your bid.
- (2) Bids must be submitted in the bidder's full legal name, or the bidder's full legal name plus a registered assumed name, if any.
- (3) All NYS bidders are required to be registered to do business with the NYS Department of State or their local County Clerk, whichever is applicable.
- (4) All out-of-state bidders will be required to provide proof of registration to do business in their state. All out-of-state bidders that "do business in New York State" **MUST BE REGISTERED WITH THE NYS DEPARTMENT OF STATE**. Please contact the NYS Department of State at (518) 473-2492. Information is available at the DOS website: www.dos.ny.gov
- (5) DASNY is required by law to notify the Empire State Development of any procurement contract for one million dollars or more that is to be awarded to an out-of-state vendor. This notice must be done simultaneous to the notification of award provided to the vendor. A purchase order or contract cannot be issued until fifteen (15) days after such notification is provided.
- (6) Empire State Development is required by law to identify states and other jurisdictions that impose preferences or other penalties against New York bidders. DASNY is precluded from soliciting bids or entering into procurement contracts with companies that have their principal place of business located in one of the listed jurisdictions, unless the procurement is for a product that is substantially manufactured in New York State or the services are to be performed in New York State. Currently, this list of jurisdictions includes the states of Alaska, Hawaii, Louisiana, South Carolina, West Virginia and Wyoming.
- (7) Unless otherwise indicated, any reference to brands or model numbers is intended to establish a standard. Items of all manufacturers will be considered, provided the item is determined to meet or exceed the required specification. DASNY's decision as to whether a substitute item meets specification will be final. Your attention is directed to Article II-7, Page 5 of the General Conditions. In order to evaluate substitute items, detailed specifications must be submitted for any product that is other than the one(s) specified in the bid.



GENERAL SPECIFICATIONS CONTINUED

- (8) Unless otherwise noted, guarantee on all items is to be one year as detailed in Article XVI of the General Conditions
- (9) All upholstered furniture and drapery panels and lining must meet strict flammability requirements. Standards applicable to this bid, if any, will be delineated in the Detailed Specifications.
- (10) LABOR/TRADES - Any labor, materials or means whose employment, or utilization during the course of this contract, shall not in any way cause or result in strike, work stoppages, delays, suspension of work; or similar troubles by workers employed by this contractor or his subcontractors, or by any of the trades working in or about the buildings and premises where work is being performed. Any violation by the contractor of this requirement may in the sole judgment of DASNY be considered as proper and sufficient cause for declaring the contractor to be in default, and for the owner to take action against him as set forth in the Purchasing General Conditions, Article VIII, "Termination", or such other action as DASNY may deem proper.
- (11) Bid results are available on the DASNY website (www.DASNY.org). Bid results will not be given over the phone.
- (12) If you are a NYS Certified Minority or Women Owned Business, please include a copy of your certification with the bid.



DASNY

ANDREW M. CUOMO
Governor

ALFONSO L. CARNEY, JR.
Chair

GERRARD P. BUSHELL, Ph.D.
President & CEO

SUPPLEMENTAL SPECIFICATIONS

The following items are attached for informational purposes. Referenced documents need not be returned with the proposal. These documents are only applicable to the successful bidder and the ensuing procurement contract. Documents are only applicable to the successful bidder and the ensuing procurement contract. Documents applicable to the procurement that will result from this Invitation for Bids are designated by a check box (☒). Unless otherwise indicated, the referenced documents are located at the end of this Invitation for Bids.

- ☒ **Purchasing General Conditions** – The DASNY Purchasing General Conditions contains terms and conditions of purchases made by DASNY. It is recommended that this document be reviewed fully.
- ☒ **M/WBE Utilization Plan and Request for Waiver** - Minority and Women-Owned Business Enterprise (M/WBE) goals for this project are 15% and 15%, respectively. The successful bidder shall be required to complete a Utilization Plan or Request for Waiver, to be approved by DASNY’s Opportunity Programs Group. Reference Purchasing General Conditions, Article XIX, Affirmative Action for Contracts Mr. Michael Clay, DASNY Opportunity Programs Group at (518) 257-3464, is available to assist all bidders in attaining these goals. *Reference the enclosed “Good Faith Efforts Guidelines”.*
- ☒ **Supplemental General Requirements** – Attached (if applicable) are the Supplemental General Requirements (SGRs) which provide important logistical information and additional conditions which govern this procurement. Please read these SGRs carefully.
- ☒ **Form of DASNY Contract** – The procurement resulting from the Invitation for Bids will be executed through a DASNY purchase order and a related contract. The contract executed with the successful bidder will be in the same substantial form as the attached “Form of Contract”. Note that this Invitation for Bids and any response to such will be annexed as binding terms of the purchase agreement.
- ☒ **Certificate of Insurance** (*sample enclosed*) – The successful bidder will be required to provide a Certificate of Insurance pursuant to Article XIV of the enclosed Purchasing General Conditions. The certificate shall name DASNY and other designated parties as additional insureds.

CORPORATE HEADQUARTERS
515 Broadway
Albany, NY 12207-2964

T 518-257-3000
F 518-257-3100

NEW YORK CITY OFFICE
One Penn Plaza, 52nd Floor
New York, NY 10119-0098

T 212-273-5000
F 212-273-5121

BUFFALO OFFICE
539 Franklin Street
Buffalo, NY 14202-1109

T 716-884-9780
F 716-884-9787

DORMITORY AUTHORITY STATE OF NEW YORK

**WE FINANCE, BUILD AND
DELIVER.**

www.dasny.org



DASNY

ANDREW M. CUOMO
Governor

ALFONSO L. CARNEY, JR.
Chair

GERRARD P. BUSHELL, Ph.D.
President & CEO

SUPPLEMENTAL SPECIFICATIONS CONTINUED

- Worker’s Compensation / Disability Insurance** – The successful proposer will be required to provide specific documentation with respect to Worker’s Compensation and Disability Insurance pursuant to Article XIV of the enclosed Purchasing General Conditions. Requirements are detailed in the enclosed “Workers’ Compensation and Disability Benefits Requirements” document.

- Prevailing Wage Schedule** – NYS Labor Law requires all wages paid by contractors and subcontractors on public work projects be paid at the prevailing wage rates. Enclosed is the current rate schedule for the appropriate county. Contractors and Subcontractors are responsible for obtaining current rates throughout the course of the project. The NYS Department of Labor (NYS DOL) updates these rates on July 1st of each year. Current rates can be obtained on the NYS DOL website (www.labor.state.ny.us) or by fax at (518) 485-1870. Note that an executed Contractor and Subcontractor Certification and certified payrolls, which include the hours and days worked by each workman, laborer or mechanic, the occupation at which he worked, the hourly wage rate paid and the supplements paid or provided, must be submitted with each and every payment requisition. **DASNY will not process an invoice without this information.** Forms are available on the DASNY website:
<http://www.dasny.org/construc/forms2/vendors.php>

- Labor and Material Payment Bond** – The successful bidder must be prepared to provide surety bonds prior to award in accordance with Article XIV of the DASNY Purchasing General Conditions. The costs of these bonds are to be separately stated in the total bid price as indicated on the Bid Breakdown and Schedule.

- Performance Bond** – The Successful bidder must be prepared to provide surety bonds prior to award in accordance with Article XIV of DASNY Purchasing General Conditions. The costs of these bonds are to be separately stated in the total bid price as indicated on the Bid Breakdown and Schedule.

- Standard Vendor Responsibility Questionnaire (SVRQ)** – The successful proposer, in accordance with Article XXII of DASNY Purchasing General Conditions, will be required to complete the enclosed SVRQ. The award of a contract will be subject to a review of the information contained in these forms.

CORPORATE HEADQUARTERS
515 Broadway
Albany, NY 12207-2964

NEW YORK CITY OFFICE
One Penn Plaza, 52nd Floor
New York, NY 10119-0098

BUFFALO OFFICE
539 Franklin Street
Buffalo, NY 14202-1109

DORMITORY AUTHORITY STATE OF NEW YORK

WE FINANCE, BUILD AND DELIVER.

T 518-257-3000
F 518-257-3100

T 212-273-5000
F 212-273-5121

T 716-884-9780
F 716-884-9787

www.dasny.org



DASNY

ANDREW M. CUOMO
Governor

ALFONSO L. CARNEY, JR.
Chair

GERRARD P. BUSHELL, Ph.D.
President & CEO

SUPPLEMENTAL SPECIFICATIONS CONTINUED

- NYS Uniform Contracting Questionnaire (UCQ)** – The successful proposer will be required to complete the enclosed UCQ. The award of a contract will be subject to a review of the information contained in these forms.

- DASNY Contractor and Consultant Questionnaire (CCQ)** – The successful proposer will be required to complete the enclosed CCQ. The award of a contract will be subject to a review of the information contained in these

CORPORATE HEADQUARTERS
515 Broadway
Albany, NY 12207-2964

T 518-257-3000
F 518-257-3100

NEW YORK CITY OFFICE
One Penn Plaza, 52nd Floor
New York, NY 10119-0098

T 212-273-5000
F 212-273-5121

BUFFALO OFFICE
539 Franklin Street
Buffalo, NY 14202-1109

T 716-884-9780
F 716-884-9787

DORMITORY AUTHORITY STATE OF NEW YORK

**WE FINANCE, BUILD AND
DELIVER.**

www.dasny.org

SUPPLEMENTAL GENERAL REQUIREMENTS

PRE-BID CONFERENCE and REQUESTS FOR INFORMATION

PRE-BID CONFERENCE:

DATE: June 11, 2018

TIME: 10 a.m.

LOCATION: Lehman College
250 Bedford Park Blvd. West
Bronx, New York
Contact: Chris Wuest (646) 773-0081

DIRECTIONS: Confirm Attendance with kcstell@dasny.org

ATTENDANCE AT THIS MEETING IS RECOMMENDED.

Hardhats and proper footwear will be required to tour the site.

REQUESTS FOR INFORMATION:

DATE: All requests for information should be submitted to purchasing@dasny.org no later than **June 13, 2018**. The bid number must be referenced in the subject line.
All responses will be posted to www.dasny.org as an Addendum to Bid No. 611 no later than **June 18, 2018**. It is the responsibility of the bidder to obtain any and all Addenda issued.

REQUIREMENT:

All bidders must be authorized to install Sedia Seating product. Confirmation of authorization will be confirmed with Sedia Seating prior to award.



DETAILED SPECIFICATIONS

**PURCHASE ORDER NO.
204169-000 OP**

Page 1

BILL TO:
D A S N Y
DORMITORY AUTHORITY STATE OF NEW YORK

**515 Broadway
ATT: ACCOUNTS PAYABLE
Albany, New York 12207
(518) 257-3000**

BID/CONTRACT NO.

PC66464

Delivery Week of: 07/31/18

DATE: 05/23/18

161678
TO:VRD Contracting Inc
ATTN: Mark J. Jozefowski
25 Andrea Rd
Holbrook NY 11741

121300
SHIP TO:
Lehman College-CUNY
250 Bedford Park Blvd. West
ATTN: Rene Rotolo, 718-960-8226
Bronx NY 104681589

FOB - Destination

Vendor Tel. No. (917) 822-9005

DELIVERY TERMS: Coordinate Delivery w/ College

DIRECT QUESTIONS TO: Costello, Kristen J.

NO CHANGE ORDER SHALL BE HONORED WITHOUT WRITTEN PERMISSION

| ITEM | DESCRIPTION | QUANTITY | UM | PRICE | AMOUNT |
|------|--|----------|----|-------|--------|
| | <p>20915 B1 W N N</p> <p>The Dormitory Authority's prompt payment policy requires the following:</p> <ol style="list-style-type: none"> 1. All invoice information must match DASNY's purchase order for payment to be issued. Invoices must be submitted to ACCOUNTS PAYABLE at the "Bill To" address above, referencing the DASNY's PO number. 2. A signed receiving report, authorizing payment from the "Ship To" facility. <p>...</p> <p>All packing slips shall clearly identify purchase order number and tagging information.</p> <p>For orders valued at \$15,000 or more, the Owner reserves the right to terminate this purchase order in the event it is found that the certification filed by the vendor in accordance with State Finance Law, S139 as such may be amended or modified, was intentionally false or intentionally incomplete. Upon such finding, the owner may exercise its termination right, such termination constituting a termination for cause, by providing written notification to the Contractor in accordance with the terms of Article VIII.1 - Termination for Cause of the Purchasing General Conditions.</p> <p>Electronic Payments Program - The Authority reserves the right to implement an electronic payment program for all payments due to the Contractor.</p> <p>The complete General Conditions are incorporated by reference and available on: www.dasny.org/PurchasingGeneralConditions.pdf DASNY's Code of Ethics are available on: www.dasny.org/sites/default/files/inline-files/2018CodeofBusinessEthics.pdf Please direct questions to individual named above.</p> | | | | |

The Dormitory Authority of the State of New York is an Equal Opportunity Employer, and encourages the utilization and participation of Minority and Women-Owned Businessess when purchasing goods and services

**PURCHASE ORDER NO.
204169-000 OP**

Page 2

BILL TO:
DASNY
DORMITORY AUTHORITY STATE OF NEW YORK

515 Broadway
ATT: ACCOUNTS PAYABLE
Albany, New York 12207
(518) 257-3000

BID/CONTRACT NO.

PC66464

Delivery Week of: 07/31/18

DATE: 05/23/18

161678
TO:VRD Contracting Inc
ATTN: Mark J. Jozefowski
25 Andrea Rd
Holbrook NY 11741

121300
SHIP TO:
Lehman College-CUNY
250 Bedford Park Blvd. West
ATTN: Rene Rotolo, 718-960-8226
Bronx NY 104681589

FOB - Destination

Vendor Tel. No. (917) 822-9005

DELIVERY TERMS: Coordinate Delivery w/ College

DIRECT QUESTIONS TO: Costello, Kristen J.

NO CHANGE ORDER SHALL BE HONORED WITHOUT WRITTEN PERMISSION

| ITEM | DESCRIPTION | QUANTITY | UM | PRICE | AMOUNT |
|------|---|----------|----|--------|------------|
| 1 | 3024109209 1332 715 Furnish Sedia Seating product per NYS OGS Contract PC66464, DASNY RFQ Issued 5/21/18 and VRD's quote per DASNY RFQ dated 5/22/18 & specifications by Sedia Seating #59944. Q Mercury Sedia Systems Mercury Auditorium Chair | 2194 | EA | 204.70 | 449,111.80 |
| 2 | 3024100999 1332 715 Q Mercury Sedia Systems Mercury Auditorium Chair - ADA Movable | 34 | EA | 241.50 | 8,211.00 |
| 3 | 3024109209 1332 715 Q-Aisle Light - Sedia Systems Aisle light | 164 | EA | 149.50 | 24,518.00 |
| 4 | 3024109209 1332 715 Q-Transformer 12 Watt, 1 Amp | 164 | EA | 89.70 | 14,710.80 |
| 5 | 3024100999 1332 715 | 300 | EA | 7.36 | 2,208.00 |

The Dormitory Authority of the State of New York is an Equal Opportunity Employer, and encourages the utilization and participation of Minority and Women-Owned Businessess when purchasing goods and services

**PURCHASE ORDER NO.
204169-000 OP**

Page 3

BILL TO:
DASNY
DORMITORY AUTHORITY STATE OF NEW YORK

**515 Broadway
ATT: ACCOUNTS PAYABLE
Albany, New York 12207
(518) 257-3000**

BID/CONTRACT NO.

PC66464

Delivery Week of: 07/31/18

DATE: 05/23/18

161678
TO:VRD Contracting Inc
ATTN: Mark J. Jozefowski
25 Andrea Rd
Holbrook NY 11741

121300
SHIP TO:
Lehman College-CUNY
250 Bedford Park Blvd. West
ATTN: Rene Rotolo, 718-960-8226
Bronx NY 104681589

FOB - Destination

Vendor Tel. No. (917) 822-9005

DELIVERY TERMS: Coordinate Delivery w/ College

DIRECT QUESTIONS TO: Costello, Kristen J.

NO CHANGE ORDER SHALL BE HONORED WITHOUT WRITTEN PERMISSION

| ITEM | DESCRIPTION | QUANTITY | UM | PRICE | AMOUNT |
|------|--|----------|----|-------|-----------|
| 6 | Q-Row Letter Round Row Letter 3024109209 1332 715 Q Seat No. NOTES: 1) DELIVERY SHALL BE COORDINATED WITH RENE ROTOLO, 718-960-8226. PLEASE COORDINATE/SCHEDULE 48 HOURS IN ADVANCE. 2) ALL PACKING SLIPS SHOULD INCLUDE THE PO NO. TO ENSURE PROPER PAYMENT. 3) CHRIS WUEST, DASNY SHALL APPROVAL ALL PAYMENTS. ALL PAYMENTS TO BE MADE BY DASNY. ... A COPY of invoice must ALSO be sent to the following address for asset management purposes only: The City University of New York Attn: Adriana Lau Office of the University Controller 230 W 41st Street, 5th Floor New York, New York 10036 ... PAYMENT OF THIS ORDER TO BE MADE BY DORMITORY AUTHORITY - STATE OF NEW YORK | 2228 | EA | 5.52 | 12,298.56 |

The Dormitory Authority of the State of New York is an Equal Opportunity Employer, and encourages the utilization and participation of Minority and Women-Owned Businessess when purchasing goods and services

PURCHASE ORDER NO.
204169-000 OP

Page 4

BILL TO:
D A S N Y
DORMITORY AUTHORITY STATE OF NEW YORK

515 Broadway
ATT: ACCOUNTS PAYABLE
Albany, New York 12207
(518) 257-3000

BID/CONTRACT NO.

PC66464

Delivery Week of: 07/31/18

DATE: 05/23/18

161678
TO:VRD Contracting Inc
 ATTN: Mark J. Jozefowski
 25 Andrea Rd
 Holbrook NY 11741

121300
SHIP TO:
 Lehman College-CUNY
 250 Bedford Park Blvd. West
 ATTN: Rene Rotolo, 718-960-8226
 Bronx NY 104681589

FOB - Destination

Vendor Tel. No. (917) 822-9005

DELIVERY TERMS: Coordinate Delivery w/ College

DIRECT QUESTIONS TO: Costello, Kristen J.

NO CHANGE ORDER SHALL BE HONORED WITHOUT WRITTEN PERMISSION

| ITEM | DESCRIPTION | QUANTITY | UM | PRICE | AMOUNT |
|--------------|-------------|----------|----|-------|------------|
| TOTAL | | | | | 511,058.16 |

Ann C. Crislip

AUTHORIZED SIGNATURE

The Dormitory Authority of the State of New York is an Equal Opportunity Employer, and encourages the utilization and participation of Minority and Women-Owned Businesses when purchasing goods and services

FIELD CHECK REQUIREMENTS

*ALL ROOM MEASUREMENTS MUST BE VERIFIED O.K. OR CROSSED-OUT & CHANGED TO THE CORRECT DIMENSION.

FIELD CHECK PERFORMED BY:

SIGNATURE:

TITLE: _____

DATE: _____

DIMENSION HERE THIS AREA FROM UPPER LEVEL

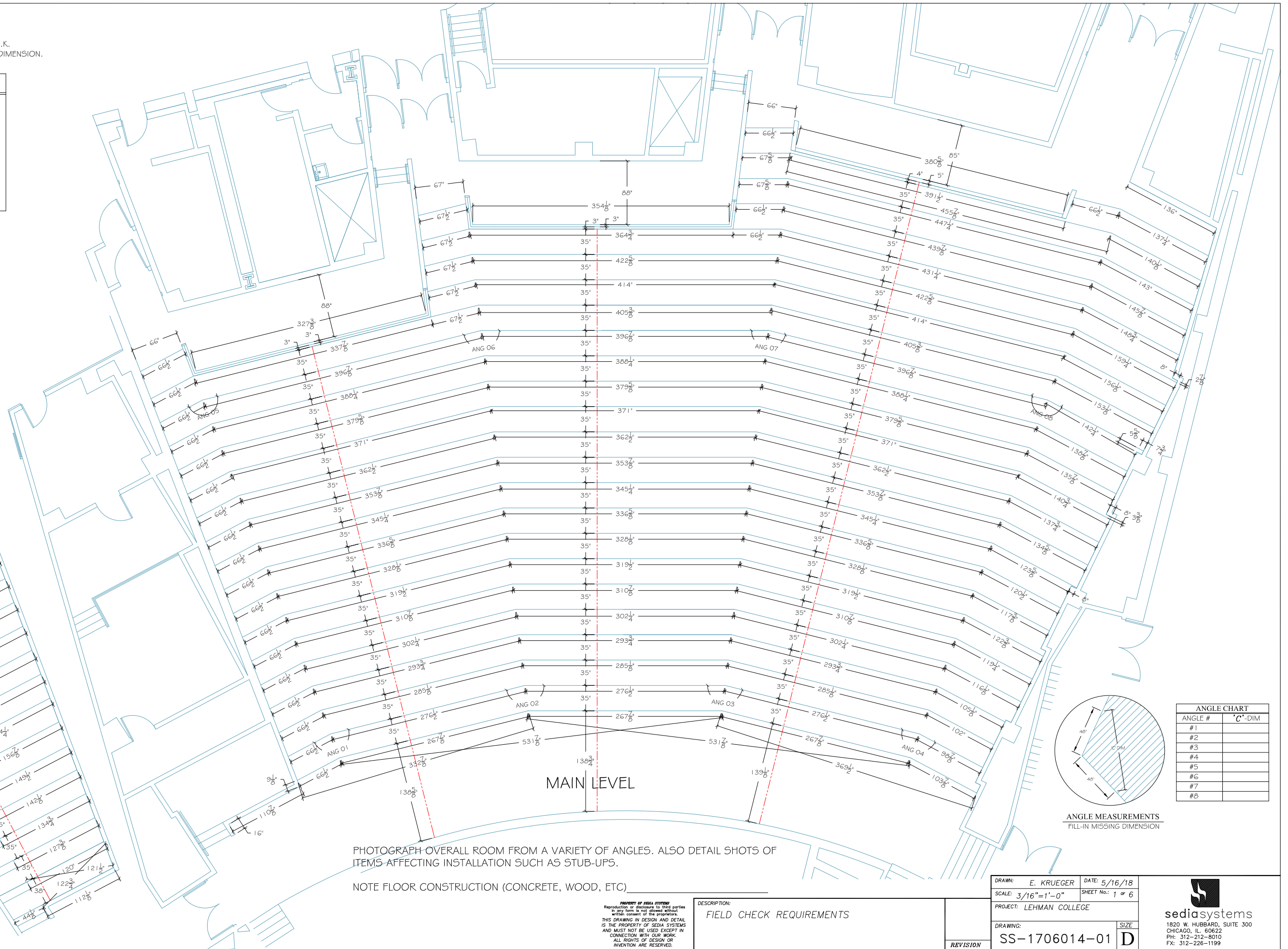
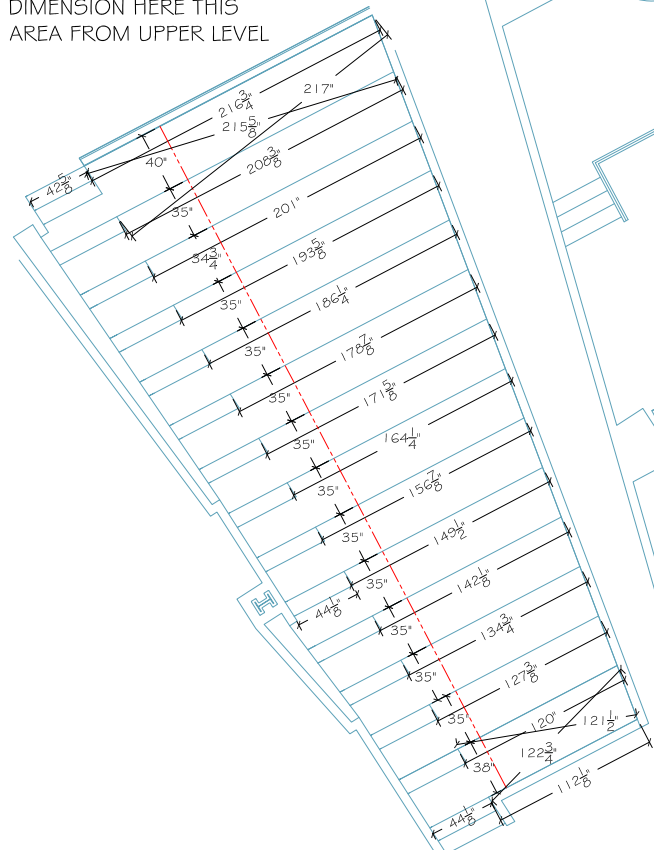

PHOTOGRAPH OVERALL ROOM FROM A VARIETY OF ANGLES. ALSO DETAIL SHOTS OF ITEMS AFFECTING INSTALLATION SUCH AS STUB-UPS.

NOTE FLOOR CONSTRUCTION (CONCRETE, WOOD, ETC)

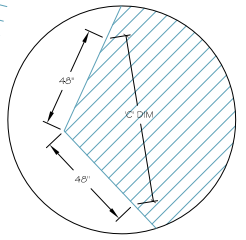

| ANGLE CHART | |
|-------------|---------|
| ANGLE # | 'C'-DIM |
| #1 | |
| #2 | |
| #3 | |
| #4 | |
| #5 | |
| #6 | |
| #7 | |
| #8 | |

ANGLE MEASUREMENTS
FILL-IN MISSING DIMENSION

PROPERTY OF SEDA SYSTEMS
Reproduction of dimensions to third parties in any form is not allowed without written consent of the proprietor.
THIS DRAWING IN DESIGN AND DETAIL IS THE PROPERTY OF SEDA SYSTEMS AND MUST NOT BE USED EXCEPT IN CONNECTION WITH OUR WORK. ALL RIGHTS OF DESIGN OR INVENTION ARE RESERVED.

DESCRIPTION:
FIELD CHECK REQUIREMENTS

| | |
|-------------------------|------------------|
| DRAWN: E. KRUEGER | DATE: 5/16/18 |
| SCALE: 3/16"=1'-0" | SHEET No: 1 of 6 |
| PROJECT: LEHMAN COLLEGE | |
| DRAWING: SS-1706014-01 | SIZE: D |
| REVISION | |

sediasystems
1820 W. HUBBARD, SUITE 300
CHICAGO, IL 60622
PH: 312-212-8010
FX: 312-226-1199

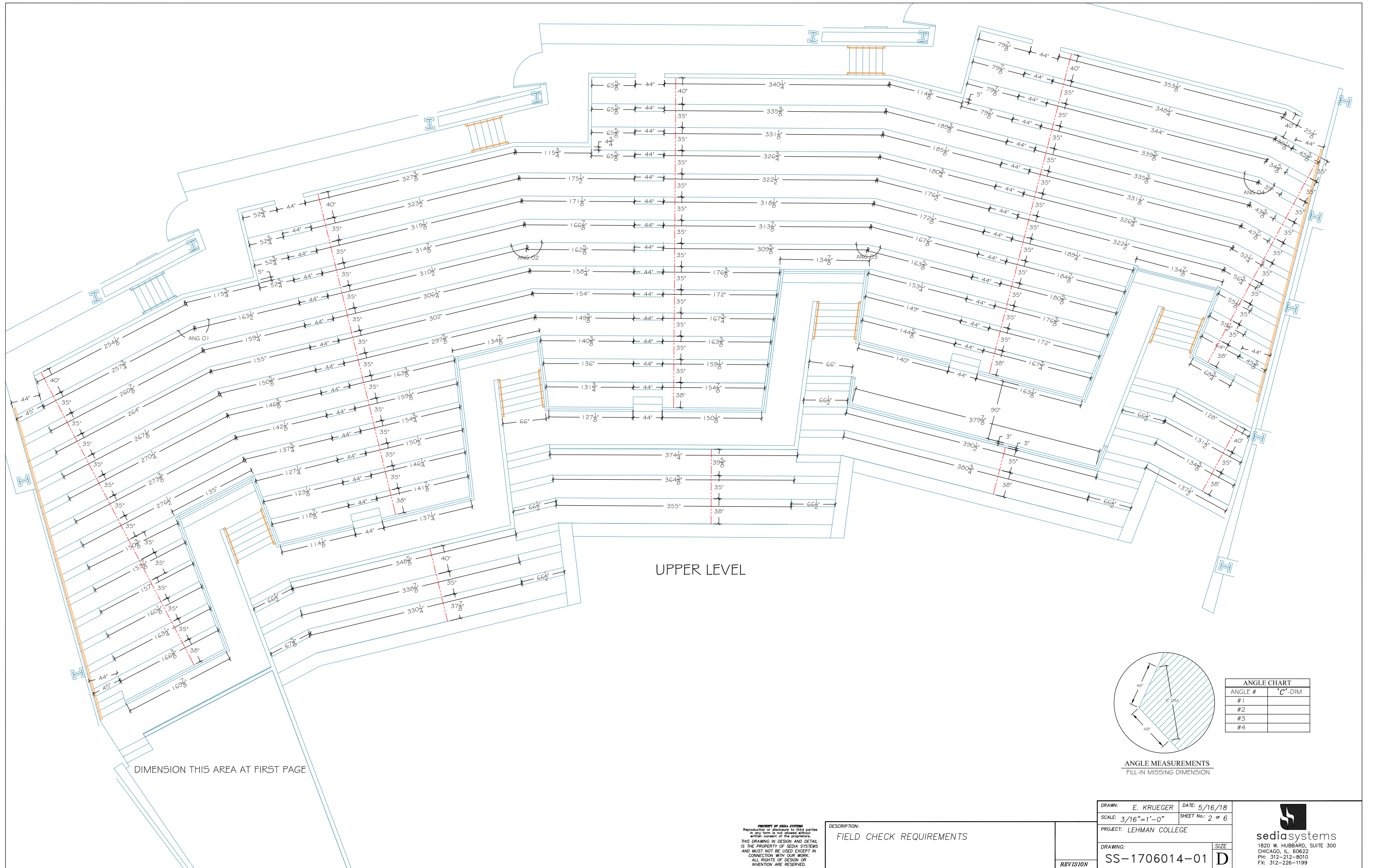

UPPER LEVEL

DIMENSION THIS AREA AT FIRST PAGE

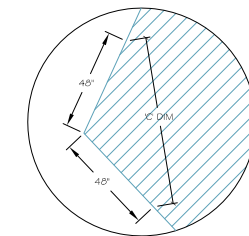

| ANGLE CHART | |
|-------------|---------|
| ANGLE # | 'C'-DIM |
| #1 | |
| #2 | |
| #3 | |
| #4 | |

ANGLE MEASUREMENTS
FILL-IN MISSING DIMENSION

PROPERTY OF SEDIA SYSTEMS
Reproduction or disclosure to third parties
in any form is not allowed without
written consent of the proprietor.
THIS DRAWING IN DESIGN AND DETAIL
IS THE PROPERTY OF SEDIA SYSTEMS
AND MUST NOT BE USED EXCEPT IN
CONNECTION WITH OUR WORK.
ALL RIGHTS OF DESIGN OR
INVENTION ARE RESERVED.

DESCRIPTION:
FIELD CHECK REQUIREMENTS

REVISION

| | | | |
|----------|----------------|------------|---------|
| DRAWN: | E. KRUEGER | DATE: | 5/16/18 |
| SCALE: | 3/16"=1'-0" | SHEET No.: | 2 of 6 |
| PROJECT: | LEHMAN COLLEGE | | |
| DRAWING: | SS-1706014-01 | SIZE: | D |

sediasystems
1820 W. HUBBARD, SUITE 300
CHICAGO, IL 60622
PH: 312-212-8010
FX: 312-226-1199



DIMENSION HERE THIS AREA FROM UPPER LEVEL

MAIN LEVEL

● EXISTING JUNCTION BOX

PROPERTY OF SEDIA SYSTEMS
 Reproduction of dimensions to third parties
 in any form is not allowed without
 written consent of the programmer.
 THIS DRAWING IN DESIGN AND DETAIL
 IS THE PROPERTY OF SEDIA SYSTEMS
 AND MUST NOT BE USED EXCEPT IN
 CONNECTION WITH OUR WORK.
 ALL RIGHTS OF DESIGN OR
 INVENTION ARE RESERVED.

| | |
|--------------|--------------------------|
| DESCRIPTION: | FIELD CHECK REQUIREMENTS |
| REVISION | |

| | | | |
|----------|----------------|------------|---------|
| DRAWN: | E. KRUEGER | DATE: | 5/16/18 |
| SCALE: | 3/16"=1'-0" | SHEET No.: | 3 of 6 |
| PROJECT: | LEHMAN COLLEGE | | |
| DRAWING: | SS-1706014-01 | SIZE: | D |

sediasystems
 1820 W. HUBBARD, SUITE 300
 CHICAGO, IL 60622
 PH: 312-212-8010
 FX: 312-226-1199

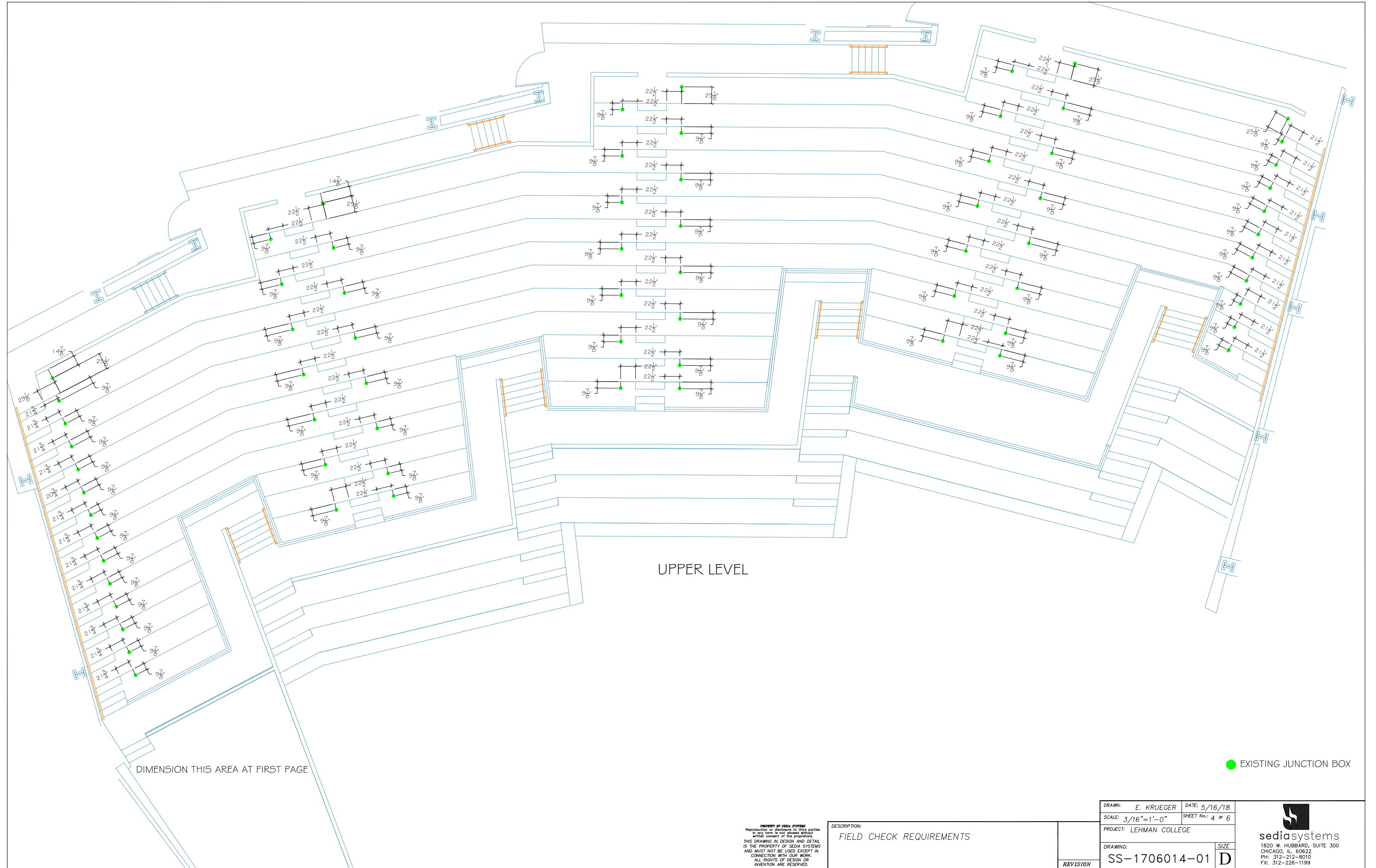

UPPER LEVEL

DIMENSION THIS AREA AT FIRST PAGE

● EXISTING JUNCTION BOX

PROPERTY OF SEDIA SYSTEMS
Reproduction or disclosure to third parties
in any form is not allowed without
written consent of the originator.
THIS DRAWING IN DESIGN AND DETAIL
IS THE PROPERTY OF SEDIA SYSTEMS
AND MUST NOT BE USED EXCEPT IN
CONNECTION WITH OUR WORK.
ALL RIGHTS OF DESIGN OR
INVENTION ARE RESERVED.

DESCRIPTION:
FIELD CHECK REQUIREMENTS

REVISION

| | |
|-------------------------|-------------------|
| DRAWN: E. KRUEGER | DATE: 5/16/18 |
| SCALE: 3/16"=1'-0" | SHEET No.: 4 of 6 |
| PROJECT: LEHMAN COLLEGE | |
| DRAWING: SS-1706014-01 | SIZE: D |

sediasystems
1820 W. HUBBARD, SUITE 300
CHICAGO, IL 60622
PH: 312-212-9010
FX: 312-226-1199

DIMENSION HERE THIS AREA FROM UPPER LEVEL

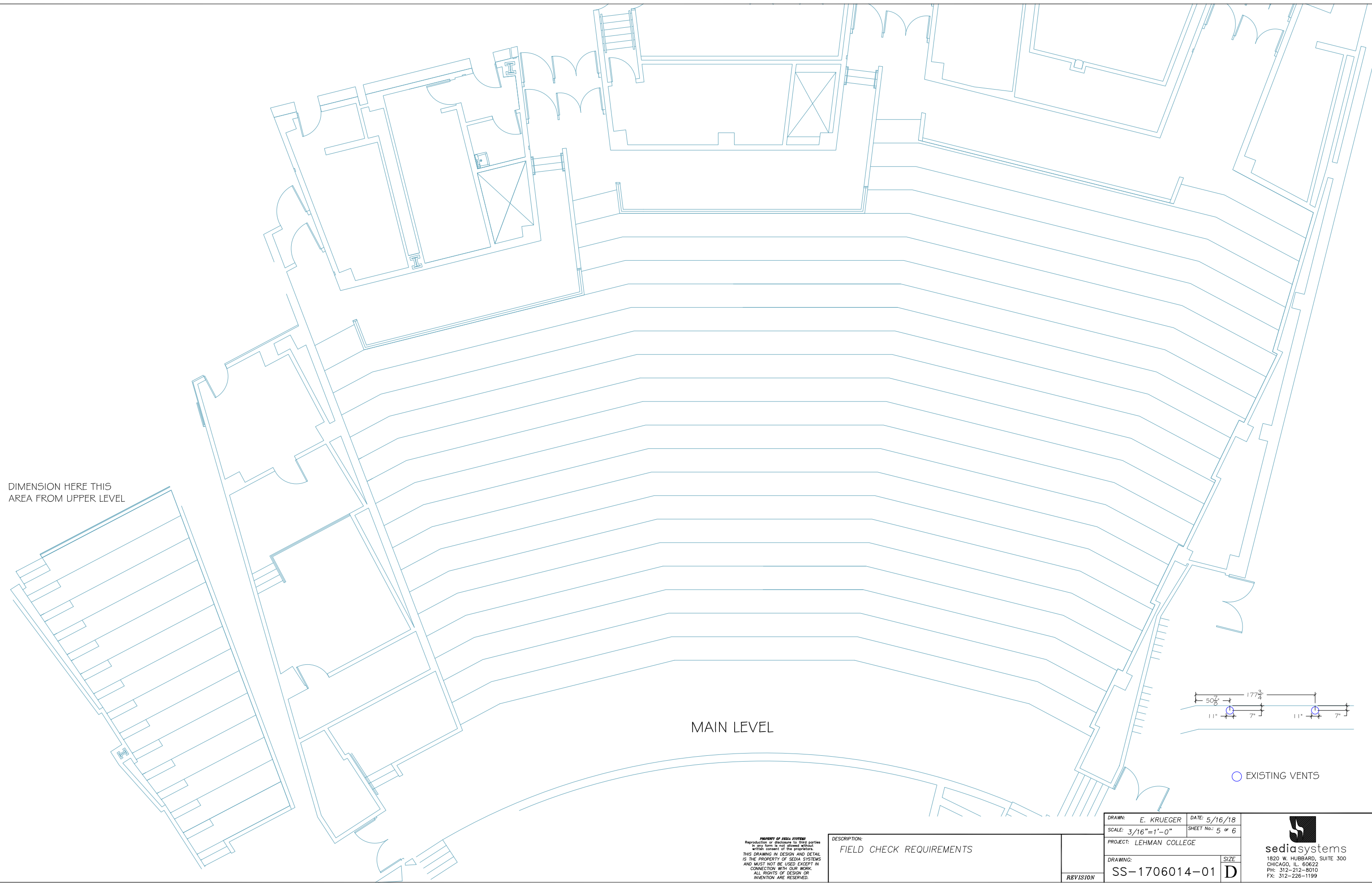

MAIN LEVEL

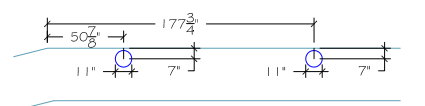

○ EXISTING VENTS

PROPERTY OF SEDIA SYSTEMS
 Reproduction of drawings to third parties
 in any form is not allowed without
 written consent of the proprietor.
 THIS DRAWING IN DESIGN AND DETAIL
 IS THE PROPERTY OF SEDIA SYSTEMS
 AND MUST NOT BE USED EXCEPT IN
 CONNECTION WITH OUR WORK.
 ALL RIGHTS OF DESIGN OR
 INVENTION ARE RESERVED.

DESCRIPTION:
 FIELD CHECK REQUIREMENTS

REVISION

| | |
|-------------------------|-------------------|
| DRAWN: E. KRUEGER | DATE: 5/16/18 |
| SCALE: 3/16"=1'-0" | SHEET No.: 5 of 6 |
| PROJECT: LEHMAN COLLEGE | |
| DRAWING: SS-1706014-01 | SIZE: D |



sediasystems
 1820 W. HUBBARD, SUITE 300
 CHICAGO, IL 60622
 PH: 312-212-8010
 FX: 312-226-1199

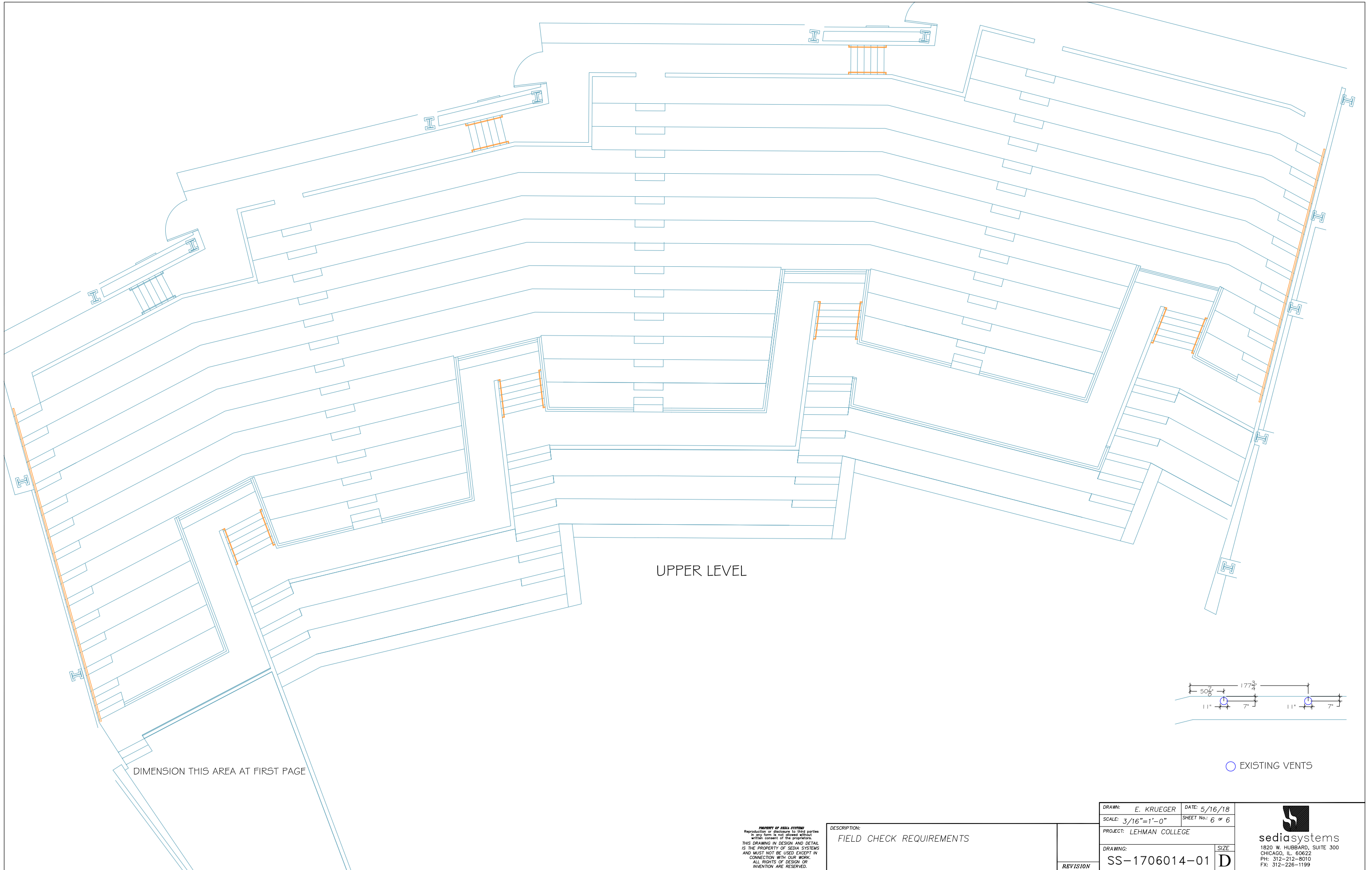

UPPER LEVEL

DIMENSION THIS AREA AT FIRST PAGE

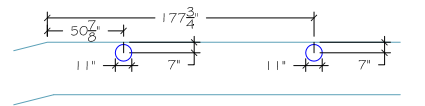

○ EXISTING VENTS

PROPERTY OF SEDIA SYSTEMS
 Reproduction of documents to third parties
 in any form is not allowed without
 written consent of the proprietor.
 THIS DRAWING IN DESIGN AND DETAIL
 IS THE PROPERTY OF SEDIA SYSTEMS
 AND MUST NOT BE USED EXCEPT IN
 CONNECTION WITH OUR WORK.
 ALL RIGHTS OF DESIGN OR
 INVENTION ARE RESERVED.

DESCRIPTION:
 FIELD CHECK REQUIREMENTS

REVISION

| | |
|-------------------------|-------------------|
| DRAWN: E. KRUEGER | DATE: 5/16/18 |
| SCALE: 3/16"=1'-0" | SHEET No.: 6 of 6 |
| PROJECT: LEHMAN COLLEGE | |
| DRAWING: SS-1706014-01 | SIZE: D |

sediasystems
 1820 W. HUBBARD, SUITE 300
 CHICAGO, IL 60622
 PH: 312-212-8010
 FX: 312-226-1199

2228 TOTAL POSITIONS

- 966 MERCURY POSITIONS AT MAIN LEVEL
- 28 MERCURY MOVABLE AT ADA LOCATIONS AT MAIN LEVEL
- 1228 MERCURY POSITIONS AT UPPER LEVEL
- 6 MERCURY MOVABLE AT ADA LOCATIONS AT UPPER LEVEL

| APPROVAL / SIGN-OFF | |
|---------------------------|-------------------------------|
| <input type="checkbox"/> | - APPROVED NO CHANGES |
| <input type="checkbox"/> | - CHANGE AS NOTED & RE-SUBMIT |
| APPROVAL SIGNATURE: _____ | |
| TITLE: _____ | |
| DATE: _____ | |

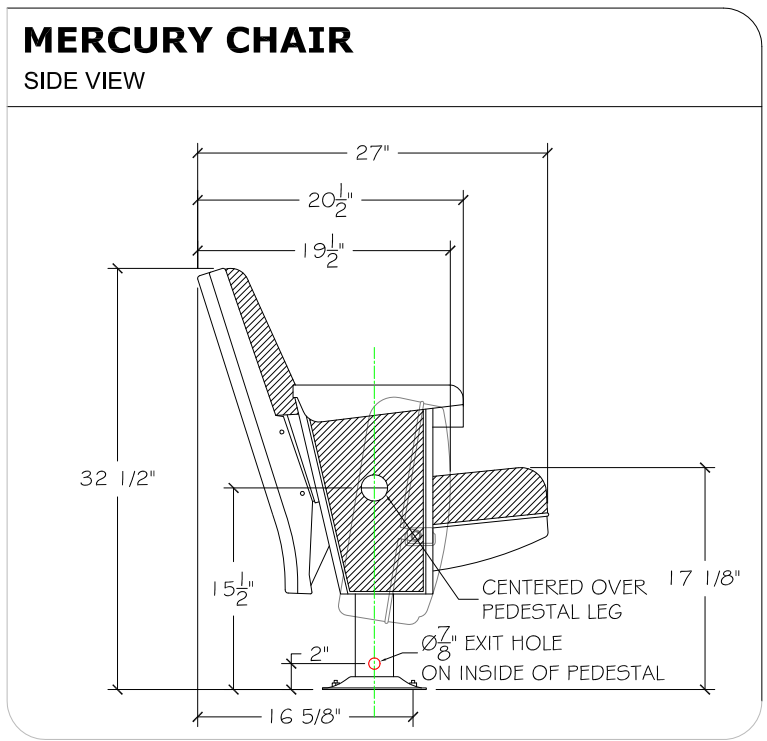
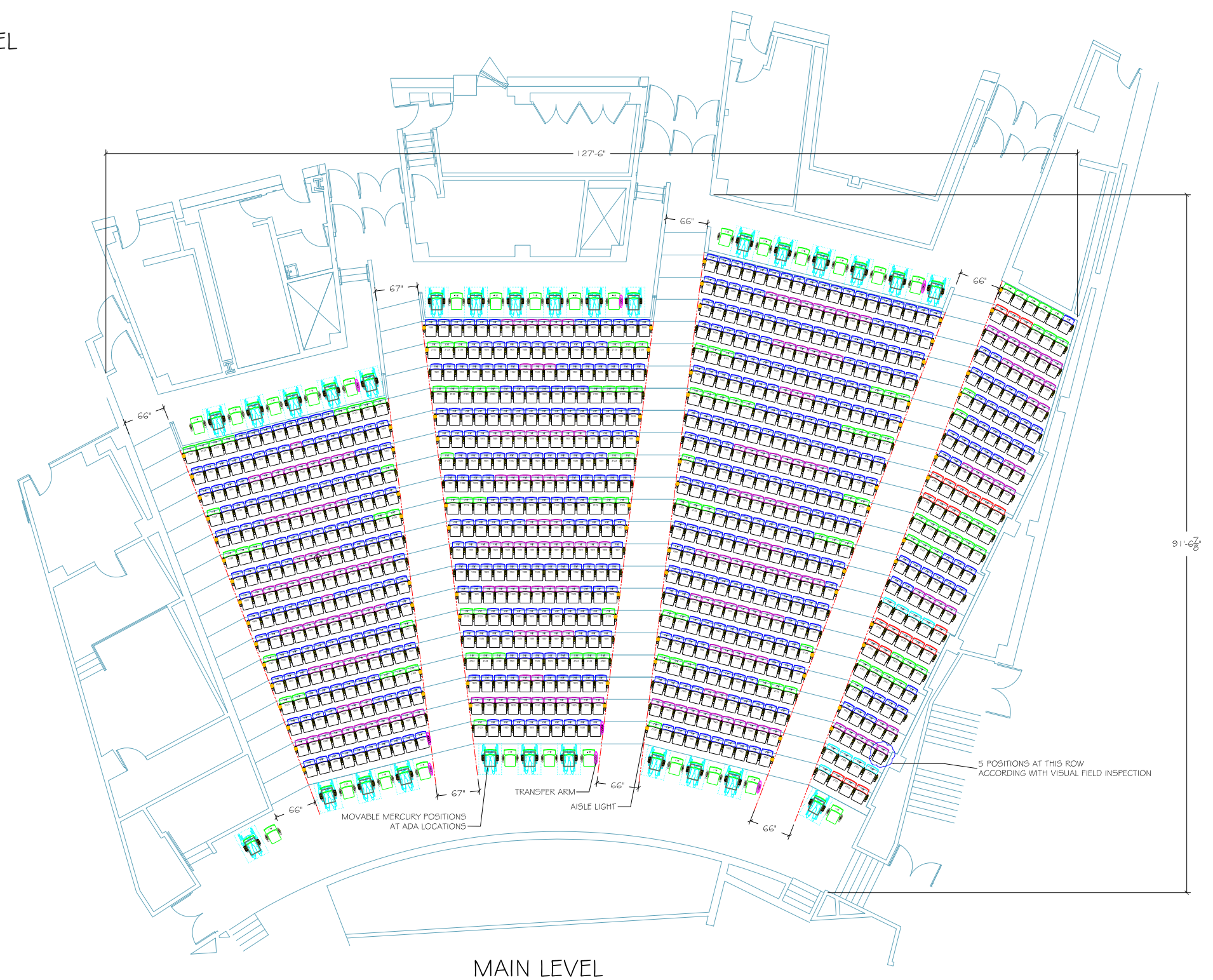

PROPERTY OF SEDIA SYSTEMS
Reproduction or disclosure to third parties in any form is not allowed without written consent of the proprietor.
THIS DRAWING IN DESIGN AND DETAIL IS THE PROPERTY OF SEDIA SYSTEMS AND MUST NOT BE USED EXCEPT IN CONNECTION WITH OUR WORK.
ALL RIGHTS OF DESIGN OR INVENTION ARE RESERVED.

DESCRIPTION:
MERCURY AUDITORIUM SEATING

2
REVISION

| | |
|-------------------------|------------------|
| DRAWN: E. KRUEGER | DATE: 5/25/18 |
| SCALE: 1/8"=1'-0" | SHEET No: 1 of 2 |
| PROJECT: LEHMAN COLLEGE | |
| DRAWING: SS-1706014-01 | SIZE: D |

sediasystems
1820 W. HUBBARD, SUITE 300
CHICAGO, IL 60622
PH: 312-212-8010
FX: 312-226-1199

2228 TOTAL POSITIONS

- 966 MERCURY POSITIONS AT MAIN LEVEL
- 28 MERCURY MOVABLE AT ADA LOCATIONS AT MAIN LEVEL
- 1228 MERCURY POSITIONS AT UPPER LEVEL
- 6 MERCURY MOVABLE AT ADA LOCATIONS AT UPPER LEVEL

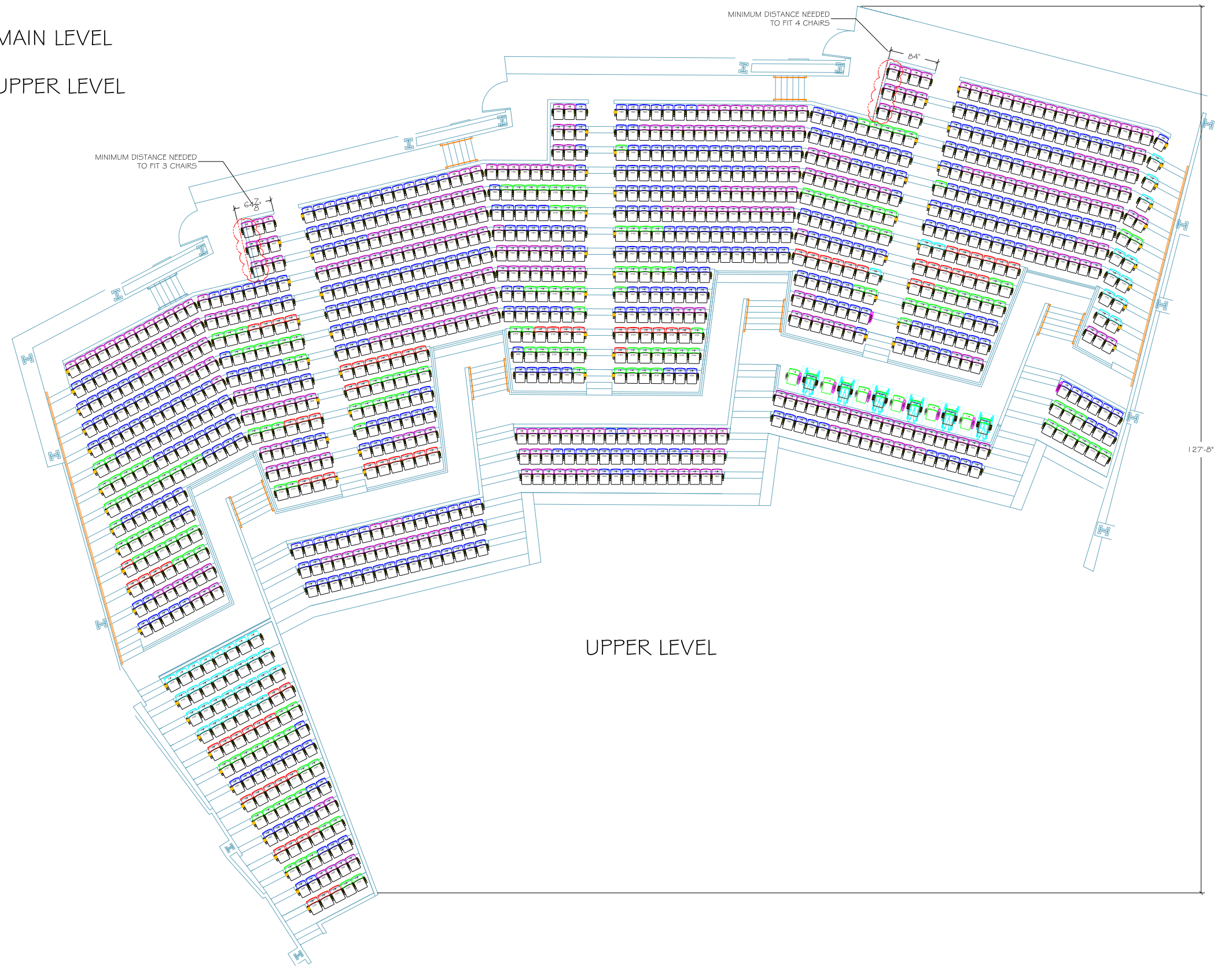

MERCURY CHAIR

SIDE VIEW

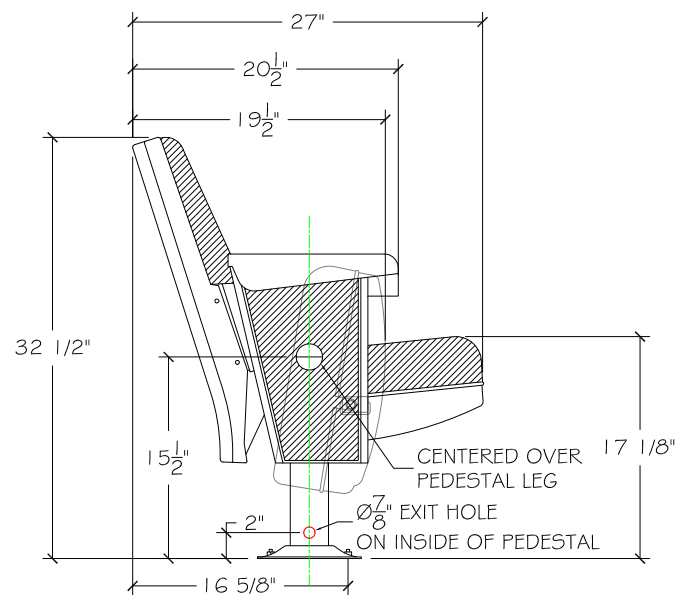

PROPERTY OF SEDIA SYSTEMS
 Reproduction or disclosure to third parties
 in any form is not allowed without
 written consent of the proprietor.
 THIS DRAWING IN DESIGN AND DETAIL
 IS THE PROPERTY OF SEDIA SYSTEMS
 AND MUST NOT BE USED EXCEPT IN
 CONNECTION WITH OUR WORK.
 ALL RIGHTS OF DESIGN OR
 INVENTION ARE RESERVED.

DESCRIPTION:
 MERCURY AUDITORIUM SEATING

2
 REVISION

| | |
|-------------------------|-------------------|
| DRAWN: E. KRUEGER | DATE: 5/25/18 |
| SCALE: 1/8"=1'-0" | SHEET No.: 2 of 2 |
| PROJECT: LEHMAN COLLEGE | |
| DRAWING: SS-1706014-01 | SIZE: D |

sediasystems
 1820 W. HUBBARD, SUITE 300
 CHICAGO, IL 60622
 PH: 312-212-8010
 FX: 312-226-1199