



**DASNY**

# **SECTION A**



BID NO.:626

PROJECT NAME & LOCATION CUNY Central

25 West 43rd Street, New  
York, NY

Description: Furnish, Deliver & Install Herman Miller Furniture

Bid Open Location: DASNY

515 Broadway, Albany, New

York Bid Open Date: February 20, 2019

Bid Open Time: 2:30 p.m.

Contact: Kristen Costello (518) 257-3119

## NOTICE TO BIDDERS

### **MAIL BIDS EARLY**

Sealed bids will be received by DASNY at the above address for the items listed in the attached Bid Breakdown and Schedule. When submitting your bid you must:

1. Prepare your bid on the attached Bid Breakdown and Schedule. Return one signed original of the Bid Breakdown and Schedule
2. If your bid deviates from Specifications, explain such deviations or qualifications on your letterhead, setting forth therein such explanations, and attach them to the Bid Breakdown and Schedule.
3. Submission of a bid constitutes full knowledge and acceptance of all provisions of the Notice to Bidders, all information referenced in the Purchasing General Conditions, Supplemental and Detailed Specifications, the Bid Submission and any Supplemental General Requirements contained herein, as well as any addenda issued in relation to the Invitation for Bids.
4. Each bid shall bear on the outside of the envelope the name of the bidder, address, telephone number and designated as a bid for the following:

DASNY Bid No. 626 -

Bid Opening Date: February 20, 2019 @ 2:30PM

Return to:

DASNY

Attn: Purchasing Unit

515 Broadway

Albany, NY 12207-2964



Bid No.: 626

When a sealed bid is placed inside another delivery jacket, the bid delivery jacket must be clearly marked on the outside “**BID ENCLOSED**” and “**ATTENTION: PURCHASING UNIT**”. The Dormitory Authority will not be responsible for receipt of bids which do not comply with these instructions.

5. Mail bid responses early in order for them to be received before the time of the bid opening. **Late bids will be automatically rejected.** Individuals submitting bids in person or by private delivery services should allow sufficient time for processing through building security to assure that the bids are received prior to the deadline for submitting bids. All individuals who plan to attend bid openings will be required to present government-issued picture identification to building security officials and obtain a visitor’s pass prior to attending the bid opening.
  
6. In accordance with State Finance Law § 139-j and 139-k, this solicitation includes and imposes certain restrictions on communications between Dormitory Authority personnel and an Offerer during this procurement process. Designated contact for this solicitation is: Kristen Costello, Sr. Purchasing Coordinator , at Dormitory Authority – State of New York, 515 Broadway, Albany, NY 12207,(518) 257-3119. Contacts made to other Dormitory Authority Personnel regarding this procurement may disqualify the Offerer and affect future procurements with governmental entities in the State of New York. Please refer to the Authority’s website [www.dasny.org](http://www.dasny.org) for Authority policy and procedures regarding this law, or the NYS office of General Services website [www.ogs.ny.gov/BU/PC/](http://www.ogs.ny.gov/BU/PC/) for more information about this law.



Bid No.: 626

**If you are not submitting a bid it is requested that you complete and return the lower portion of this form**

*(Please check all that apply and provide comments in the space provided, if necessary)*

We are not Submitting a bid.

We Request removal of our name from the mailing list.

Location of the job site.

Commodity is not carried by our company.

Scope is too large.

Other/Additional Explanation: \_\_\_\_\_

\_\_\_\_\_

NAME OF BIDDER: \_\_\_\_\_

ADDRESS \_\_\_\_\_

:

Street Telephone

City

State

Zip

\_\_\_\_\_  
Signature of Bidder

\_\_\_\_\_  
Official Title

## **CLAUSES PURSUANT TO THE OMNIBUS PROCUREMENT ACT OF 1992**

It is the policy of New York State to maximize opportunities for the participation of New York State business enterprises, including minority and woman-owned business enterprises as bidders, subcontractors and suppliers on its procurement contracts.

Information on the availability of New York subcontractors and supplies is available from:

Empire State Development  
Small Business Division  
30 South Pearl Street, 7<sup>th</sup> Floor  
Albany, NY 12207  
Phone: (800) 782-8369

A directory of minority and woman-owned business enterprises is available from:

Empire State Development  
Division of Minority and Women Business Development  
30 South Pearl Street  
Albany, NY 12207  
Phone: (518) 292-5250

Online Directory: <https://ny.newnycontracts.com/FrontEnd/VendorSearchPublic.asp>

[DASNY maintains a directory of minority and women-owned business enterprises:  
http://www.dasny.org/construc/mwsberreg/index.php](http://www.dasny.org/construc/mwsberreg/index.php)

The contractor acknowledges notice that New York State may seek to obtain offset credits from foreign countries as a result of this contract and agrees to cooperate with the State in these efforts.

DASNY encourages the use of recycled Materials in the manufacturing process. To that end, the recycled product must meet the same codes, specifications and standards the non-recycled materials do, including requirements for cost, installation, aesthetics, availability and maintenance.

The Omnibus Procurement Act of 1992 and § 2879 of the NYS Public Authorities Law require that by signing this bid, contractors certify that whenever the total bid amount is greater than \$1 million:

1. The contractor has made reasonable efforts to encourage the participation of New York State Business Enterprises as suppliers and Subcontractors on this project, and has retained the documentation of these efforts to be provided upon request to the State. If the contractor determines that NYS business enterprises are not available to participate on the contract as subcontractors or suppliers, the contractor shall provide a statement indicating the method by which such determination was made. If the contractor does not intend to use subcontractors, contractor shall provide a statement verifying such;
2. The contractor has complied with the Federal Equal Opportunity Act of 1972 (PL 92-261), as amended;
3. The contractor agrees to make reasonable efforts to provide notification to New York State residents of employment opportunities on this project through listing any such positions with the Job Service Division of the New York State Department of Labor, or providing such notification in such manner as is consistent with existing collective bargaining contracts or agreements. The contractor agrees to document these efforts and to provide said documentation to the State upon request;

**DASNY is required by law to notify the NYS Department of Economic Development of any procurement contract for one million dollars or more that is to be awarded to an out-of-state vendor. This notice must be done simultaneous to the notification of award provided to the vendor. A purchase order or contract cannot be issued until fifteen (15) days after such notification is provided.**



**DASNY**

---

## GENERAL SPECIFICATIONS

- (1) The enclosed Purchasing General Conditions are hereby incorporated by reference. Submission of a bid response shall constitute acceptance of such conditions. Any exceptions/clarifications/qualifications to these conditions or other specifications and/or requirements contained herein must be clearly stated in the bid response and, depending upon the nature of such, may be grounds for rejection of your bid.
- (2) Bids must be submitted in the bidder's full legal name, or the bidder's full legal name plus a registered assumed name, if any.
- (3) All NYS bidders are required to be registered to do business with the NYS Department of State or their local County Clerk, whichever is applicable.
- (4) All out-of-state bidders will be required to provide proof of registration to do business in their state. All out-of-state bidders that "do business in New York State" **MUST BE REGISTERED WITH THE NYS DEPARTMENT OF STATE**. Please contact the NYS Department of State at (518) 473-2492. Information is available at the DOS website: [www.dos.ny.gov](http://www.dos.ny.gov)
- (5) DASNY is required by law to notify the Empire State Development of any procurement contract for one million dollars or more that is to be awarded to an out-of-state vendor. This notice must be done simultaneous to the notification of award provided to the vendor. A purchase order or contract cannot be issued until fifteen (15) days after such notification is provided.
- (6) Empire State Development is required by law to identify states and other jurisdictions that impose preferences or other penalties against New York bidders. DASNY is precluded from soliciting bids or entering into procurement contracts with companies that have their principal place of business located in one of the listed jurisdictions, unless the procurement is for a product that is substantially manufactured in New York State or the services are to be performed in New York State. Currently, this list of jurisdictions includes the states of Alaska, Hawaii, Louisiana, South Carolina, West Virginia and Wyoming.
- (7) Unless otherwise indicated, any reference to brands or model numbers is intended to establish a standard. Items of all manufacturers will be considered, provided the item is determined to meet or exceed the required specification. DASNY's decision as to whether a substitute item meets specification will be final. Your attention is directed to Article II-7, Page 5 of the General Conditions. In order to evaluate substitute items, detailed specifications must be submitted for any product that is other than the one(s) specified in the bid.



**DASNY**

---

## GENERAL SPECIFICATIONS CONTINUED

- (8) Unless otherwise noted, guarantee on all items is to be one year as detailed in Article XVI of the General Conditions
- (9) All upholstered furniture and drapery panels and lining must meet strict flammability requirements. Standards applicable to this bid, if any, will be delineated in the Detailed Specifications.
- (10) LABOR/TRADES - Any labor, materials or means whose employment, or utilization during the course of this contract, shall not in any way cause or result in strike, work stoppages, delays, suspension of work; or similar troubles by workers employed by this contractor or his subcontractors, or by any of the trades working in or about the buildings and premises where work is being performed. Any violation by the contractor of this requirement may in the sole judgment of DASNY be considered as proper and sufficient cause for declaring the contractor to be in default, and for the owner to take action against him as set forth in the Purchasing General Conditions, Article VIII, "Termination", or such other action as DASNY may deem proper.
- (11) Bid results are available on the DASNY website ([www.DASNY.org](http://www.DASNY.org)). Bid results will not be given over the phone.
- (12) If you are a NYS Certified Minority or Women Owned Business, please include a copy of your certification with the bid.





**DASNY**

**ANDREW M. CUOMO**  
Governor

**ALFONSO L. CARNEY, JR.**  
Chair

**GERRARD P. BUSHELL, Ph.D.**  
President & CEO

## SUPPLEMENTAL SPECIFICATIONS

**The following items are attached for informational purposes. Referenced documents need not be returned with the proposal.** These documents are only applicable to the successful bidder and the ensuing procurement contract. Documents are only applicable to the successful bidder and the ensuing procurement contract. Documents applicable to the procurement that will result from this Invitation for Bids are designated by a check box (☒). Unless otherwise indicated, the referenced documents are located at the end of this Invitation for Bids.

- ☒ **Purchasing General Conditions** – The DASNY Purchasing General Conditions contains terms and conditions of purchases made by DASNY. It is recommended that this document be reviewed fully.
- ☒ **M/WBE Utilization Plan and Request for Waiver** - Minority and Women-Owned Business Enterprise (M/WBE) goals for this project are 18% and 12%, respectively. The successful bidder shall be required to complete a Utilization Plan or Request for Waiver, to be approved by DASNY’s Opportunity Programs Group. Reference Purchasing General Conditions, Article XIX, Affirmative Action for Contracts Mr. Michael Clay, DASNY Opportunity Programs Group at (518) 257-3464, is available to assist all bidders in attaining these goals. *Reference the enclosed “Good Faith Efforts Guidelines”.*
- ☒ **Supplemental General Requirements** – Attached (if applicable) are the Supplemental General Requirements (SGRs) which provide important logistical information and additional conditions which govern this procurement. Please read these SGRs carefully.
- ☒ **Form of DASNY Contract** – The procurement resulting from the Invitation for Bids will be executed through a DASNY purchase order and a related contract. The contract executed with the successful bidder will be in the same substantial form as the attached “Form of Contract”. Note that this Invitation for Bids and any response to such will be annexed as binding terms of the purchase agreement.
- ☒ **Certificate of Insurance** (*sample enclosed*) – The successful bidder will be required to provide a Certificate of Insurance pursuant to Article XIV of the enclosed Purchasing General Conditions. The certificate shall name DASNY and other designated parties as additional insureds.

**CORPORATE HEADQUARTERS**  
515 Broadway  
Albany, NY 12207-2964

T 518-257-3000  
F 518-257-3100

**NEW YORK CITY OFFICE**  
One Penn Plaza, 52nd Floor  
New York, NY 10119-0098

T 212-273-5000  
F 212-273-5121

**BUFFALO OFFICE**  
539 Franklin Street  
Buffalo, NY 14202-1109

T 716-884-9780  
F 716-884-9787

**DORMITORY AUTHORITY STATE OF NEW YORK**

**WE FINANCE, BUILD AND  
DELIVER.**

[www.dasny.org](http://www.dasny.org)



**DASNY**

**ANDREW M. CUOMO**  
Governor

**ALFONSO L. CARNEY, JR.**  
Chair

**GERRARD P. BUSHELL, Ph.D.**  
President & CEO

**SUPPLEMENTAL SPECIFICATIONS CONTINUED**

- Worker’s Compensation / Disability Insurance** – The successful proposer will be required to provide specific documentation with respect to Worker’s Compensation and Disability Insurance pursuant to Article XIV of the enclosed Purchasing General Conditions. Requirements are detailed in the enclosed “Workers’ Compensation and Disability Benefits Requirements” document.
  
- Prevailing Wage Schedule** – NYS Labor Law requires all wages paid by contractors and subcontractors on public work projects be paid at the prevailing wage rates. Enclosed is the current rate schedule for the appropriate county. Contractors and Subcontractors are responsible for obtaining current rates throughout the course of the project. The NYS Department of Labor (NYS DOL) updates these rates on July 1st of each year. Current rates can be obtained on the NYS DOL website ([www.labor.state.ny.us](http://www.labor.state.ny.us)) or by fax at (518) 485-1870. Note that an executed Contractor and Subcontractor Certification and certified payrolls, which include the hours and days worked by each workman, laborer or mechanic, the occupation at which he worked, the hourly wage rate paid and the supplements paid or provided, must be submitted with each and every payment requisition. **DASNY will not process an invoice without this information.** Forms are available on the DASNY website:  
<http://www.dasny.org/construc/forms2/vendors.php>
  
- Labor and Material Payment Bond** – The successful bidder must be prepared to provide surety bonds prior to award in accordance with Article XIV of the DASNY Purchasing General Conditions. The costs of these bonds are to be separately stated in the total bid price as indicated on the Bid Breakdown and Schedule.
  
- Performance Bond** – The Successful bidder must be prepared to provide surety bonds prior to award in accordance with Article XIV of DASNY Purchasing General Conditions. The costs of these bonds are to be separately stated in the total bid price as indicated on the Bid Breakdown and Schedule.
  
- Standard Vendor Responsibility Questionnaire (SVRQ)** – The successful proposer, in accordance with Article XXII of DASNY Purchasing General Conditions, will be required to complete the enclosed SVRQ. The award of a contract will be subject to a review of the information contained in these forms.

**CORPORATE HEADQUARTERS**  
515 Broadway  
Albany, NY 12207-2964

**NEW YORK CITY OFFICE**  
One Penn Plaza, 52nd Floor  
New York, NY 10119-0098

**BUFFALO OFFICE**  
539 Franklin Street  
Buffalo, NY 14202-1109

**DORMITORY AUTHORITY STATE OF NEW YORK**

**WE FINANCE, BUILD AND DELIVER.**

T 518-257-3000  
F 518-257-3100

T 212-273-5000  
F 212-273-5121

T 716-884-9780  
F 716-884-9787

[www.dasny.org](http://www.dasny.org)



**DASNY**

**ANDREW M. CUOMO**  
Governor

**ALFONSO L. CARNEY, JR.**  
Chair

**GERRARD P. BUSHELL, Ph.D.**  
President & CEO

**SUPPLEMENTAL SPECIFICATIONS CONTINUED**

- NYS Uniform Contracting Questionnaire (UCQ)** – The successful proposer will be required to complete the enclosed UCQ. The award of a contract will be subject to a review of the information contained in these forms.
  
- DASNY Contractor and Consultant Questionnaire (CCQ)** – The successful proposer will be required to complete the enclosed CCQ. The award of a contract will be subject to a review of the information contained in these

**CORPORATE HEADQUARTERS**  
515 Broadway  
Albany, NY 12207-2964

T 518-257-3000  
F 518-257-3100

**NEW YORK CITY OFFICE**  
One Penn Plaza, 52nd Floor  
New York, NY 10119-0098

T 212-273-5000  
F 212-273-5121

**BUFFALO OFFICE**  
539 Franklin Street  
Buffalo, NY 14202-1109

T 716-884-9780  
F 716-884-9787

**DORMITORY AUTHORITY STATE OF NEW YORK**

**WE FINANCE, BUILD AND  
DELIVER.**

[www.dasny.org](http://www.dasny.org)

# Herman Miller Furniture Specifications

**Project:** CUNY Central 25w-43<sup>rd</sup>  
**Project #** 347460

**Description:** Mirra 2 Chair, Standard Height, Tilt Limiter and Seat Angle, Adjustable Non-upholstered Arms, Adjustable Seat, Triflex Back, Black Caster for Hard Floors or Carpet

**Key Number:** CH-02  
**Qty.** 21  
**Catalog Number:** MRF1.2.3.A.W.A.P.G1.C7.G1

**Manufacturer:** Herman Miller  
**Back:** Name: TriFlex Back  
 Color: G1 Graphite

**Seat:** Name: AirwareWeave 2  
 Color: G1 Graphite

**Dimensions:** 20.5"w x 22.5"d x 32.75h  
 SH: 19"

**Source Name:** Herman Miller, Inc.  
**Phone Number:** 616-654-8461  
**NYS Vendor ID No:** 1000009239  
**NYS Contract Group No:** 20915  
**NYS Vendor Contract No:** PC66271  
**NYS Contract Exp. Date:** December 1, 2018

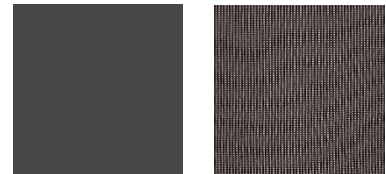

**Detailed Specifications:** Mirra 2 Chair, Standard Height, Tilt Limiter and Seat Angle, Adjustable Non-upholstered Arms, Adjustable Seat, Triflex Back, Black Caster for Hard Floors or Carpet, Graphite Seat and Back

**Delivery Method:** Inside Delivery and installation; Set-in-place, remove debris and make ready for use.

## CH-02 Distribution Locations

Floor	Suite #	Room Name	Quantity
10	1005	Office 1	1
10	1005	Office 2	1
10	1005	Office 3	1
10	1005	Office 4	1
10	1005	Office 5	1
10	1005	Office 6	1
10	1005	Open Work Area	6
10	1008	Private Office	1
10	1008	Open Work Area	3
10	1008	Storage/ Open Work Area	1
10	1010	Open Work Area	4

# Herman Miller Furniture Specifications

**Project:** CUNY Central 25w-43<sup>rd</sup>  
**Project #** 347460

**Description:** Caper Chair, Stacking, Fixed Arms, Soft Wheel Caster for Carpet or Hard Floors, and Flexnet Seat

**Key Number:** CH-03A  
**Qty.** 8  
**Catalog Number:** WC4.20.P.BK.G1.79.U5.BK

**Manufacturer:** Herman Miller  
**Back:** Name: TriFlex Back  
 Color: Green Apple

**Seat:** Name: FlexNet  
 Color: G1 Graphite

**Dimensions:** 24.25"w x 18.5"d x 32h  
 SH: 18"

**Source Name:** Herman Miller, Inc.  
**Phone Number:** 616-654-8461  
**NYS Vendor ID No:** 1000009239  
**NYS Contract Group No:** 20915  
**NYS Vendor Contract No:** PC66271  
**NYS Contract Exp. Date:** December 1, 2018

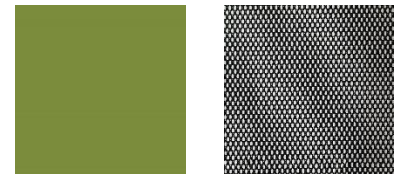

**Detailed Specifications:** Caper Chair, Stacking, Fixed Arms, Soft Wheel Caster for Carpet or Hard Floors, G1 Graphite, and Modeled Back, 79 Green Apple.

**Delivery Method:** Inside Delivery and installation; Set-in-place, remove debris and make ready for use.

## CH-03A Distribution Locations

Floor	Suite #	Room Name	Quantity
10	1010	Open Work Area	4
10	1005	Pantry	4

# Herman Miller Furniture Specifications

**Project:** CUNY Central 25w-43<sup>rd</sup>  
**Project #** 347460

**Description:** Caper Chair, Stacking, Fixed Arms, Soft Wheel Caster for Carpet or Hard Floors, and Flexnet Seat

**Key Number:** CH-03B  
**Qty.** 6  
**Catalog Number:** WC4.20.P.BK.G1.3M.U5.BK

**Manufacturer:** Herman Miller  
**Back:** Name: TriFlex Back  
 Color: Berry Blue

**Upholstery:** Name: FlexNet  
 Color: G1 Graphite

**Dimensions:** 24.25"w x 18.5"d x 32h  
 SH: 18"

**Source Name:** Herman Miller, Inc.  
**Phone Number:** 616-654-8461  
**NYS Vendor ID No:** 1000009239  
**NYS Contract Group No:** 20915  
**NYS Vendor Contract No:** PC66271  
**NYS Contract Exp. Date:** December 1, 2018

**Detailed Specifications:** Caper Chair, Stacking, Fixed Arms, Soft Wheel Caster for Carpet or Hard Floors, and Flexnet Seat, G1 graphite, and modeled back, 3M Berry Blue.

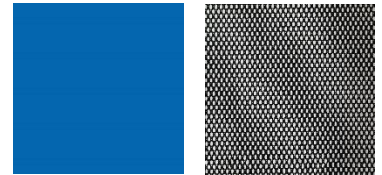

**Delivery Method:** Inside Delivery and installation; Set-in-place, remove debris and make ready for use.

## CH-03B Distribution Locations

Floor	Suite #	Room Name	Quantity
10	1008	Meeting Room	6

# Herman Miller Furniture Specifications

**Project:** CUNY Central 25w-43<sup>rd</sup>  
**Project #** 347460

**Description:** Everywhere Conference Table, Soft Rectangle, Laminate Top, No Grommet, Eames Table Base

**Key Number:** T-01A

**Qty.** 1

**Catalog Number:** Custom

**Manufacturer:** Herman Miller

**Edge:** White (91)

**Laminate:** White (91)

**Base:** Cylinder: Cool Grey Neutral  
Base: Polished Aluminum



**Dimensions:** 72"w x 42"d x 28.5"h

**Source Name:** Herman Miller, Inc.

**Phone Number:** 616-654-8461

**NYS Vendor ID No:** 1000009239

**NYS Contract Group No:** 20915

**NYS Vendor Contract No:** PC66271

**NYS Contract Exp. Date:** December 1, 2018

**Detailed Specifications:** Everywhere Conference Table, Soft Rectangle, Laminate Top, No Grommet, Eames Table Base



**Delivery Method:** Inside Delivery and installation; Set-in-place, remove debris and make ready for use.

## T-01A Distribution Locations

Floor	Suite #	Room Name	Quantity
10	1008	Meeting Room	1

# Herman Miller Furniture Specifications

**Project:** CUNY Central 25w-43<sup>rd</sup>  
**Project #** 347460

**Description:** Everywhere Conference Table, Soft Rectangle, Laminate Top, No Grommet, Eames Table Base

**Key Number:** T-01B  
**Qty.** 1  
**Catalog Number:** Custom

**Manufacturer:** Herman Miller

**Laminate:** White (91)  
**Edge:** White (91)  
**Base:** Cylinder: Cool Grey Neutral  
Base: Polished Aluminum



**Dimensions:** 66"w x 30"d x 28.5"h

**Source Name:** Herman Miller, Inc.  
**Phone Number:** 616-654-8461  
**NYS Vendor ID No:** 1000009239  
**NYS Contract Group No:** 20915  
**NYS Vendor Contract No:** PC66271  
**NYS Contract Exp. Date:** December 1, 2018

**Detailed Specifications:** Everywhere Conference Table, Soft Rectangle, Laminate Top, No Grommet, Eames Table Base

**Delivery Method:** Inside Delivery and installation; Set-in-place, remove debris and make ready for use.

## T-01B Distribution Locations

Floor	Suite #	Room Name	Quantity
10	1010	Open Work Area	1



# Herman Miller Furniture Specifications

**Project:** CUNY Central 25w-43<sup>rd</sup>  
**Project #** 347460

**Description:** Everywhere Table, Round, Laminate Top with Eames Table Base

**Key Number:** T-02  
**Qty.** 2  
**Catalog Number:** Custom

**Manufacturer:** Herman Miller

**Laminate:** White (91)  
**Edge:** White (91)  
**Base:** Cylinder: Cool Grey Neutral  
Base: Polished Aluminum



**Dimensions:** 36" diameter x 28.5"h

**Source Name:** Herman Miller, Inc.  
**Phone Number:** 616-654-8461  
**NYS Vendor ID No:** 1000009239  
**NYS Contract Group No:** 20915  
**NYS Vendor Contract No:** PC66271  
**NYS Contract Exp. Date:** December 1, 2018  
**Detailed Specifications:** Everywhere Table, Round, Laminate Top with Eames Table Base

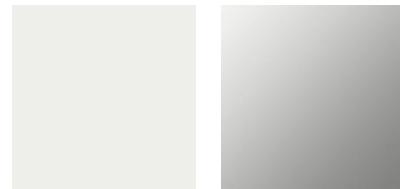

**Delivery Method:** Inside Delivery and installation; Set-in-place, remove debris and make ready for use.

## T-02 Distribution Locations

Floor	Suite #	Room Name	Quantity
10	1005	Pantry	1
10	1005	Office 6	1

# Herman Miller Furniture Specifications

**Project:** CUNY Central 25w-43<sup>rd</sup>  
**Project #** 347460

**Description:** Rectangular Worksurface with Square Open Support Legs, and Lower Storage

**Key Number:** D-01A  
**Qty.** 6

**Catalog Number:** To Consist of the Following:  
 (QTY 1) 30”d x 72”w Worksurface, center grommet  
 (QTY 2) 30” Square Open Support Leg  
 (QTY 1) 28” d Freestand Pedestal, BBF  
 (QTY 1) 72” Overhead Bin (Open) with Tack Board and Task Light

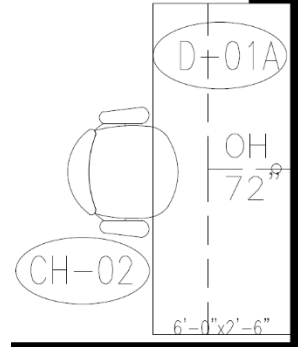

**Manufacturer:** Herman Miller

**Edge:** White  
**Laminate:** White  
**Legs/Storage:** Metallic Silver  
**Tack Board:** Upper Tile: 6”h, Pattern: Crossing; Color: Cerulean  
 Lower Tile: 17”h, Pattern: Crossing; Color: Graphite

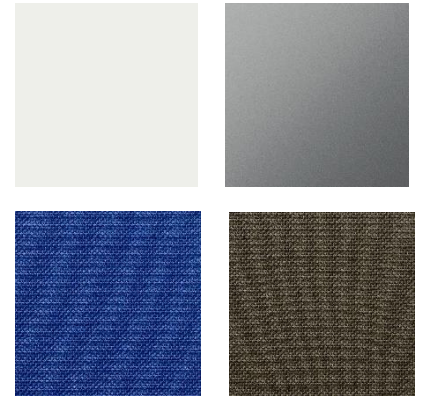

**Dimensions:** 30”d x 72”w

**Source Name:** Herman Miller, Inc.  
**Phone Number:** 616-654-8461  
**NYS Vendor ID No:** 1000009239  
**NYS Contract Group No:** 20915  
**NYS Vendor Contract No:** PC66271  
**NYS Contract Exp. Date:** December 1, 2018

**Detailed Specifications:** Rectangular Worksurface with Square Open Support Legs, and Lower Storage. Reference furniture plans for location and quantities. Components within position shall be keyed alike. Each position shall be keyed differently. Include all brackets supports, trim pieces, end caps, etc.

**Delivery Method:** Inside Delivery and installation; Set-in-place, remove debris and make ready for use.

## D-01A Distribution Locations

Floor	Suite #	Room Name	Quantity
10	1008	Open Work Area	4
10	1008	Storage/ Open Work Area	2

# Herman Miller Furniture Specifications

**Project:** CUNY Central 25w-43<sup>rd</sup>  
**Project #** 347460

**Description:** Canvas, Rectangular Worksurface with Square Open Support Legs, and Lower Storage

**Key Number:** D-01B

**Qty.** 1

**Catalog Number:** To Consist of the Following:  
 (QTY 2) 36/65 panel, upper tile and lower tile, powered  
 (QTY 2) 30" d x 72" w Worksurface, center grommet  
 (QTY 4) 30" Square Open Support Leg  
 (QTY 2) 28" d Freestand Pedestal, BBF  
 (QTY 2) 72" Overhead Bin (Open) with Task Light

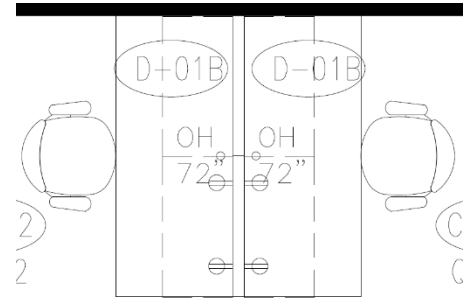

**Manufacturer:** Herman Miller

**Edge:** White

**Laminate:** White

**Legs/Storage:** Metallic Silver

**Panel:** Upper Tile: 30" h, Pattern: Crossing; Color: Cerulean  
 Lower Tile: 30" h, Metallic Silver

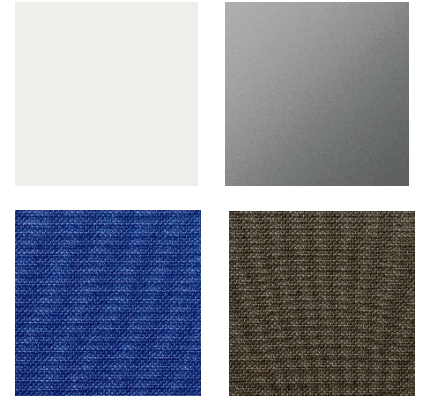

**Dimensions:** 63" d x 72" w

**Source Name:** Herman Miller, Inc.

**Phone Number:** 616-654-8461

**NYS Vendor ID No:** 1000009239

**NYS Contract Group No:** 20915

**NYS Vendor Contract No:** PC66271

**NYS Contract Exp. Date:** December 1, 2018

**Detailed Specifications:** Rectangular Worksurface with Square Open Support Legs, and Lower Storage. Reference furniture plans for location and quantities. Components within position shall be keyed alike. Each position shall be keyed differently. Include all brackets supports, trim pieces, end caps, etc.

- New York City power is required for all modular furniture.
- Panels are to be wall mounted.

**Delivery Method:** Inside Delivery and installation; Set-in-place, remove debris and make ready for use.

## D-01B Distribution Locations

Floor	Suite #	Room Name	Quantity
10	1008	Storage/ Open Work Area	1

# Herman Miller Furniture Specifications

**Project:** CUNY Central 25w-43<sup>rd</sup>  
**Project #** 347460  
**Description:** Canvas Workstation Configuration, 6' x 6'

**Key Number:** D-02  
**Qty.** 1  
**Catalog Number:** To consist of the following:  
 (QTY 2) 30/46 panel, upper tile and lower tile, powered  
 (QTY 2) 36/46 panel, upper tile and lower tile, powered  
 (QTY 2) Base Power Infeeds  
 (QTY 2) 30/46 panel, upper tile and lower tile, non-powered  
 (QTY 2) 36/46 panel, upper tile and lower tile, non-powered  
 (QTY 4) 11/66 Frameless Glass, Clear  
 (QTY 4) 30" d x 72" w Worksurface, center grommet  
 (QTY 4) 20" d x 36" w Worksurface, center grommet  
 (QTY 4) 20" Square Open Support Leg  
 (QTY 4) 30" Square Open Support Leg  
 (QTY 4) 28" d Freestand Pedestal, BBF  
 (QTY 4) 20" d Freestand Pedestal, FF  
 (QTY 4) 72" w Wall Mounted Bins (Open) with Tack Board and Task Light

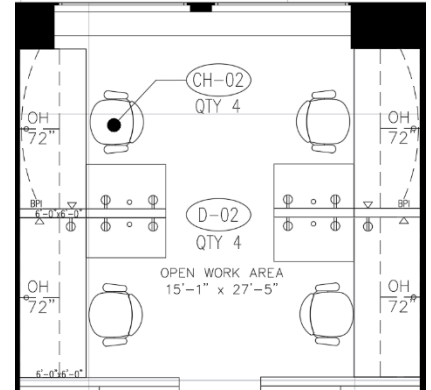

**Manufacturer:** Herman Miller  
**Edge:** 91 White  
**Laminate:** 91 White  
**Legs/Storage:** Metallic Silver  
**Powered Panels:** Upper Tile: 11" h, Pattern: Crossing; Color: Green Apple  
 Lower Tile: 30" h, Metallic Silver  
**Non-Powered Panels:** Upper Tile: 11" h, Metallic Silver  
 Lower Tile: 30" h, Metallic Silver  
**Tack Board:** Upper Tile: 6" h, Pattern: Slant; Color: Chartreuse  
 Lower Tile: 17" h, Pattern: Crossing; Color: Graphite

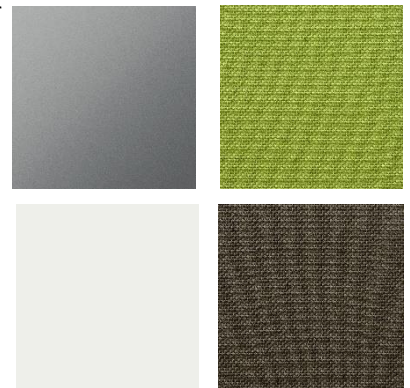

**Source Name:** Herman Miller, Inc.  
**Phone Number:** 616-654-8461  
**NYS Vendor ID No:** 1000009239  
**NYS Contract Group No:** 20915  
**NYS Vendor Contract No:** PC66271  
**NYS Contract Exp. Date:** December 1, 2018  
**Detailed Specifications:** Canvas Workstation Configuration, Powered, 6' x 6'. Reference furniture plans for location and quantities. Components within position shall be keyed alike. Each position shall be keyed differently. Include all brackets supports, trim pieces, end caps, etc.

- New York City power is required for all modular furniture.
- Panels are to be wall mounted.

**Delivery Method:** Inside Delivery and installation; Set-in-place, remove debris and make ready for use.

## D-01 Distribution Locations

Floor	Suite #	Room Name	Quantity
10	1010	Open Work Area	1

# Herman Miller Furniture Specifications

**Project:** CUNY Central 25w-43<sup>d</sup>  
**Project #** 347460

**Description:** Canvas Workstation Configuration, Non-Powered

**Key Number:** D-03A  
**Qty.** 1  
**Catalog Number:** To Consist of the Following:  
 (QTY 4) 36/46panel, upper tile and lower tile, non-powered  
 (QTY 2) 42/46 panel, upper tile and lower tile, non-powered  
 (QTY 2) 11/42 Frameless Glass, Clear (Wing Panels)  
 (QTY 2) 30"d x 72"w Worksurface, center grommet  
 (QTY 1) 20"d x 84"w Worksurface, (2) Grommets  
 (QTY 2) Post Legs  
 (QTY 2) Shared Leg  
 (QTY 2) 28" d Freestand Pedestal, BBF  
 (QTY 2) 20" d Freestand Pedestal, FF  
 (QTY 1) 72"w Wall Mounted Bin (Open) with Tack Board and Task Light  
 (QTY 1) 66"w Wall Mounted Bin (Open) with Tack Board and Task Light

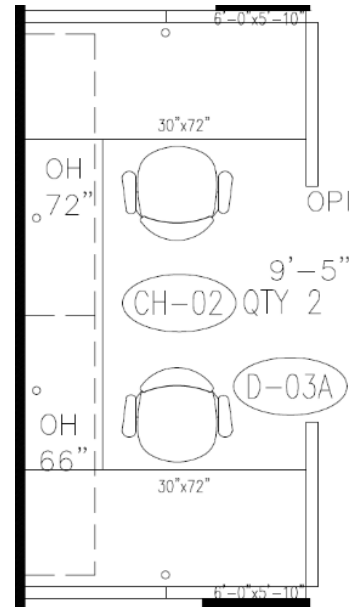

**Manufacturer:** Herman Miller

**Edge:** Oak on Ash  
**Laminate:** Oak on Ash  
**Overheads:** 91 White  
**Legs/Storage:** Metallic Silver  
**Panel Interior:** Upper Tile: 11"h, Pattern: Crossing; Color: Green Apple  
 Lower Tile: 30"h, Metallic Silver  
**Panel Exterior:** Upper Tile: 11"h, Metallic Silver  
 Lower Tile: 30"h, Metallic Silver  
**Tack Board:** Upper Tile: 6"h, Pattern: Slant; Color: Chartreuse  
 Lower Tile: 17"h, Pattern: Crossing; Color: Graphite



**Source Name:** Herman Miller, Inc.  
**Phone Number:** 616-654-8461  
**NYS Vendor ID No:** 1000009239  
**NYS Contract Group No:** 20915  
**NYS Vendor Contract No:** PC66271  
**NYS Contract Exp. Date:** December 1, 2018  
**Detailed Specifications:** Canvas Workstation Configuration, Non-Powered. Reference furniture plans for location and quantities. Components within position shall be keyed alike. Each position shall be keyed differently. Include all brackets supports, trim pieces, end caps, etc.

- 20"d x 84"w Worksurface may need to be field cut to fit space.
- Panels are to be wall mounted.

**Delivery Method:** Inside Delivery and installation; Set-in-place, remove debris and make ready for use.

## D-03A Distribution Locations

Floor	Suite #	Room Name	Quantity
10	1005	Open Work Area	1

# Herman Miller Furniture Specifications

**Project:** CUNY Central 25w-43<sup>rd</sup>  
**Project #** 347460

**Description:** Canvas Workstation Configuration, Non-Powered

**Key Number:** D-03B  
**Qty.** 1  
**Catalog Number:** To Consist of the Following:  
 (QTY 4) 36/46 panel, upper tile and lower tile, non-powered  
 (QTY 2) 42/46 panel, upper tile and lower tile, non-powered  
 (QTY 2) 11/42 Frameless Glass, Clear (Wing Panels)  
 (QTY 2) 30"d x 72"w Worksurface, center grommet  
 (QTY 1) 20"d x 72"w Worksurface, (2) grommets  
 (QTY 2) Post Legs  
 (QTY 2) Shared Leg  
 (QTY 2) 28" d Freestand Pedestal, BBF  
 (QTY 2) 20" d Freestand Pedestal, FF  
 (QTY 2) 36"w Wall Mounted Bins (Open) with Tack Board and Task Light  
 (QTY 2) 30"w Wall Mounted Bins (Open) with Tack Board and Task Light

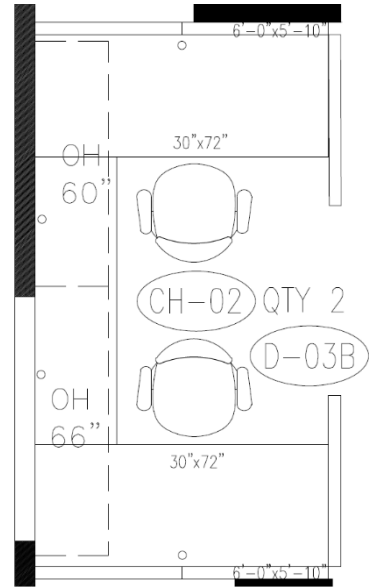

**Manufacturer:** Herman Miller

**Edge:** Oak on Ash  
**Laminate top:** Oak on Ash  
**Overheads:** 91 White  
**Legs/Storage:** Metallic Silver  
**Panel Interior:** Upper Tile: 11"h, Pattern: Crossing; Color: Green Apple  
 Lower Tile: 30"h, Metallic Silver  
**Panel Exterior:** Upper Tile: 11"h, Metallic Silver  
 Lower Tile: 30"h, Metallic Silver  
**Tack Board:** Upper Tile: 6"h, Pattern: Slant; Color: Chartreuse  
 Lower Tile: 17"h, Pattern: Crossing; Color: Graphite



**Source Name:** Herman Miller, Inc.  
**Phone Number:** 616-654-8461  
**NYS Vendor ID No:** 1000009239  
**NYS Contract Group No:** 20915  
**NYS Vendor Contract No:** PC66271  
**NYS Contract Exp. Date:** December 1, 2018  
**Detailed Specifications:** Canvas Workstation Configuration, Non-Powered. Reference furniture plans for location and quantities. Components within position shall be keyed alike. Each position shall be keyed differently. Include all brackets supports, trim pieces, end caps, etc.

- 20"d x 72"w Worksurface will need to be field cut to fit space.
- Panels are to be wall mounted.

**Delivery Method:** Inside Delivery and installation; Set-in-place, remove debris and make ready for use.

## D-03B Distribution Locations

Floor	Suite #	Room Name	Quantity
10	1005	Open Work Area	1

# Herman Miller Furniture Specifications

**Project:** CUNY Central 25w-43<sup>rd</sup>  
**Project #** 347460

**Description:** Canvas Workstation Configuration, Non-Powered

**Key Number:** D-03C  
**Qty.** 1  
**Catalog Number:** To consist of the following:  
 (QTY 4) 36/46 panel, upper tile and lower tile, non-powered  
 (QTY 2) 42/46 panel, upper tile and lower tile, non-powered  
 (QTY 2) 11/42 Frameless Glass, Clear (Wing Panels)  
 (QTY 2) 30"d x 72"w Worksurface, centered grommet  
 (QTY 1) 20"d x 78"w Worksurface, (2) grommet  
 (QTY 2) Post Legs  
 (QTY 2) Shared Leg  
 (QTY 2) 28" d Freestand Pedestal, BBF  
 (QTY 2) 20" d Freestand Pedestal, FF  
 (QTY 2) 66"w Wall Mounted Bins (Open) with Tack Board and Task Light

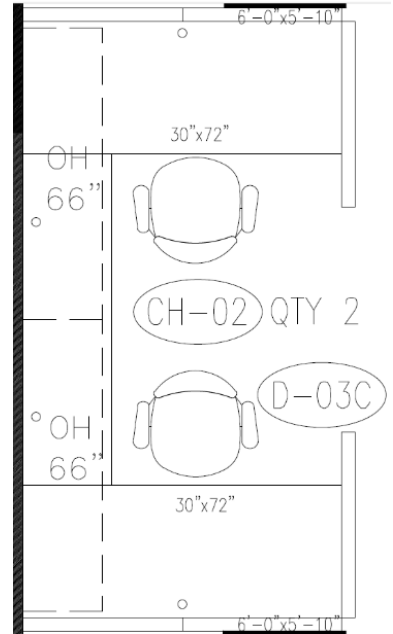

**Manufacturer:** Herman Miller

**Edge:** Oak on Ash  
**Laminate top:** Oak on Ash  
**Overheads:** 91 White  
**Legs/Storage:** Metallic Silver  
**Panel Interior:** Upper Tile: 11"h, Pattern: Crossing; Color: Green Apple  
 Lower Tile: 30"h, Metallic Silver  
**Panel Exterior:** Upper Tile: 11"h, Metallic Silver  
 Lower Tile: 30"h, Metallic Silver  
**Tack Board:** Upper Tile: 6"h, Pattern: Slant; Color: Chartreuse  
 Lower Tile: 17"h, Pattern: Crossing; Color: Graphite



**Source Name:** Herman Miller, Inc.  
**Phone Number:** 616-654-8461  
**NYS Vendor ID No:** 1000009239  
**NYS Contract Group No:** 20915  
**NYS Vendor Contract No:** PC66271  
**NYS Contract Exp. Date:** December 1, 2018  
**Detailed Specifications:** Canvas Workstation Configuration, Non-Powered. Reference furniture plans for location and quantities. Components within position shall be keyed alike. Each position shall be keyed differently. Include all brackets supports, etc.

- 20"d x 78"w Worksurface will need to be field cut to fit space.
- Panels are to be wall mounted.

**Delivery Method:** Inside Delivery and installation; Set-in-place, remove debris and make ready for use.

## D-03C Distribution Locations

Floor	Suite #	Room Name	Quantity
10	1005	Open Work Area	1

# Herman Miller Furniture Specifications

**Project:** CUNY Central 25w-43<sup>rd</sup>  
**Project #** 347460

**Description:** Canvas Workstation Configuration, Non-Powered, Left-Hand, Outbound for 30"d.

**Key Number:** D-04A  
**Qty.** 3

**Catalog Number:** To Consist of the Following:  
 (QTY 1) 30"d x 72"w Peninsula Top, rounded corners, grommet, Handed, transitional edge on guest-facing side.  
 (QTY 1) 20"d x 42"w Worksurface, center grommet  
 (QTY 1) BBF Pedestal  
 (QTY 1) 12" Translucent Plastic Screen, Below  
 (QTY 1) 72"w Wall Mounted Bins (As Shown) with Tack Board and Task Light

**Manufacturer:** Herman Miller

**Edge:** Oak on Ash  
**Laminate:** Oak on Ash  
**Overheads:** 91 White  
**Pedestal:** Metallic Silver  
**Tack Board:** Upper Tile: 6"h, Pattern: Crossing; Color: Green Apple  
 Lower Tile: 17"h, Pattern: Crossing; Color: Graphite

**Source Name:** Herman Miller, Inc.  
**Phone Number:** 616-654-8461  
**NYS Vendor ID No:** 1000009239  
**NYS Contract Group No:** 20915  
**NYS Vendor Contract No:** PC66271  
**NYS Contract Exp. Date:** December 1, 2018

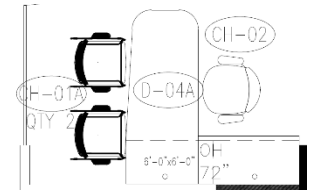
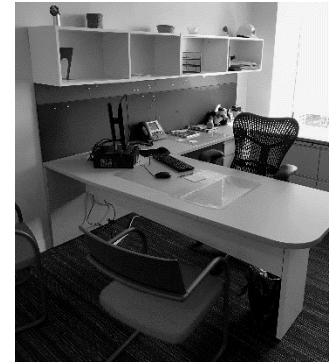

**Detailed Specifications:** Canvas Workstation Configuration, Non-Powered. Reference furniture plans for location and quantities. Components within position shall be keyed alike. Each position shall be keyed differently. Include all brackets supports, etc.

**Delivery Method:** Inside Delivery and installation; Set-in-place, remove debris and make ready for use.

### D-04A Distribution Locations

Floor	Suite #	Room Name	Quantity
10	1005	Office 1	1
10	1005	Office 2	1
10	1005	Office 6	1



# Herman Miller Furniture Specifications

**Project:** CUNY Central 25w-43<sup>rd</sup>  
**Project #** 347460

**Description:** Canvas Workstation Configuration, Non-Powered, Right-Hand, Outbound for 30"d.

**Key Number:** D-04B  
**Qty.** 2

**Catalog Number:** To Consist of the Following:  
 (QTY 1) 30"d x 72"w Peninsula Top, rounded corners, grommet, Handed, transitional edge on guest-facing side.  
 (QTY 1) 20"d x 42"w Worksurface, center grommet  
 (QTY 1) BBF Pedestal  
 (QTY 1) 12" Translucent Plastic Screen, Below  
 (QTY 1) 72"w Wall Mounted Bin (As Shown) with Tack Board and Task Light

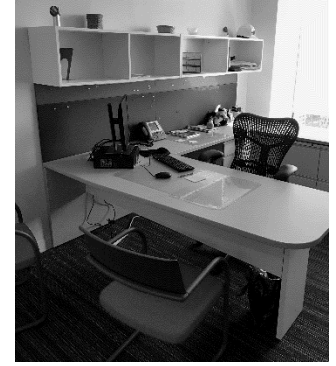

**Manufacturer:** Herman Miller

**Edge:** Oak on Ash  
**Laminate Top:** Oak on Ash  
**Overheads:** 91 White  
**Laminate Base:** 91 White  
**Pedestal:** Metallic Silver  
**Tack Board:** Upper Tile: 6"h, Pattern: Crossing; Color: Green Apple  
 Lower Tile: 17"h, Pattern: Crossing; Color: Graphite

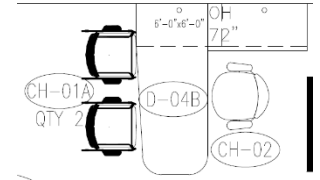

**Source Name:** Herman Miller, Inc.  
**Phone Number:** 616-654-8461  
**NYS Vendor ID No:** 1000009239  
**NYS Contract Group No:** 20915  
**NYS Vendor Contract No:** PC66271  
**NYS Contract Exp. Date:** December 1, 2018



**Detailed Specifications:** Canvas Workstation Configuration, Non-Powered. Reference furniture plans for location and quantities. Components within position shall be keyed alike. Each position shall be keyed differently. Include all brackets supports, etc.

**Delivery Method:** Inside Delivery and installation; Set-in-place, remove debris and make ready for use.

### D-04B Distribution Locations

Floor	Suite #	Room Name	Quantity
10	1005	Office 3	1
10	1005	Office 5	1

# Herman Miller Furniture Specifications

**Project:** CUNY Central 25w-43<sup>rd</sup>  
**Project #** 347460

**Description:** Canvas Workstation Configuration, Non-Powered, Right-Hand, Outbound for 30"d.

**Key Number:** D-04C  
**Qty.** 1  
**Catalog Number:** To consist of the following:  
 (QTY 1) 30"d x 72"w Peninsula Top, rounded corners, grommet, Handed, transitional edge on guest-facing side.  
 (QTY 1) 20"d x 42"w Worksurface, center grommet  
 (QTY 1) BBF Pedestal  
 (QTY 1) 12" Translucent Plastic Screen, Below

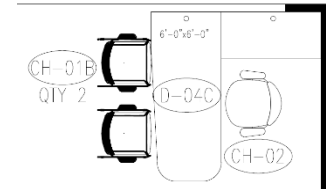

**Manufacturer:** Herman Miller

**Edge:** 91 White  
**Laminate:** 91 White  
**Pedestal:** Metallic Silver  
**Tack Board:** Upper Tile: 6"h, Pattern: Crossing; Color: Green Apple  
 Lower Tile: 17"h, Pattern: Crossing; Color: Graphite



**Source Name:** Herman Miller, Inc.  
**Phone Number:** 616-654-8461  
**NYS Vendor ID No:** 1000009239  
**NYS Contract Group No:** 20915  
**NYS Vendor Contract No:** PC66271  
**NYS Contract Exp. Date:** December 1, 2018

**Detailed Specifications:** Canvas Workstation Configuration, Non-Powered. Reference furniture plans for location and quantities. Components within position shall be keyed alike. Each position shall be keyed differently. Include all brackets supports, etc.

**Delivery Method:** Inside Delivery and installation; Set-in-place, remove debris and make ready for use.

## D-04C Distribution Locations

Floor	Suite #	Room Name	Quantity
10	1008	Private Office	1

# Herman Miller Furniture Specifications

**Project:** CUNY Central 25w-43<sup>rd</sup>  
**Project #** 347460

**Description:** Canvas Workstation Configuration, Non-Powered, Left-Hand, Outbound for 30"d.



**Key Number:** D-04D  
**Qty.** 1  
**Catalog Number:** To Consist of the Following:  
 (QTY 1) 30"d x 66"w Peninsula Top, rounded corners, grommet, Handed, transitional edge on guest-facing side.  
 (QTY 1) 20"d x 42"w Worksurface, center grommet  
 (QTY 1) BBF Pedestal  
 (QTY 1) 12" Translucent Plastic Screen, Below

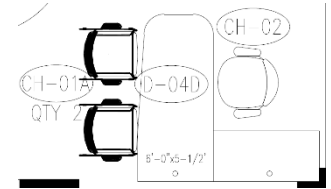

**Manufacturer:** Herman Miller

**Edge:** Oak on Ash  
**Laminate Top:** Oak on Ash  
**Overheads:** 91 White  
**Laminate Base:** 91 White  
**Pedestal:** Metallic Silver  
**Tack Board:** Upper Tile: 6"h, Pattern: Crossing; Color: Green Apple  
 Lower Tile: 17"h, Pattern: Crossing; Color: Graphite

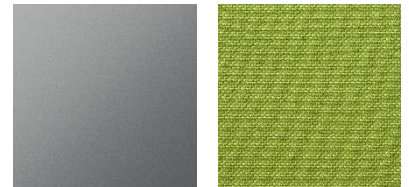

**Source Name:** Herman Miller, Inc.  
**Phone Number:** 616-654-8461  
**NYS Vendor ID No:** 1000009239  
**NYS Contract Group No:** 20915  
**NYS Vendor Contract No:** PC66271  
**NYS Contract Exp. Date:** December 1, 2018

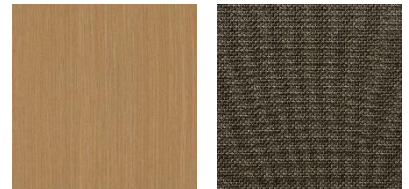

**Detailed Specifications:** Canvas Workstation Configuration, Non-Powered. Reference furniture plans for location and quantities. Components within position shall be keyed alike. Each position shall be keyed differently. Include all brackets supports, etc.

**Delivery Method:** Inside Delivery and installation; Set-in-place, remove debris and make ready for use.

### D-04D Distribution Locations

Floor	Suite #	Room Name	Quantity
10	1005	Office 4	1